



**SMART
WASP**

**SMART WASP
M Type Turntable
Fully Automatic Pallet
Wrapping Machine
Model: X500**

Operation and Maintenance Instructions

Content

1 Basic Information.....	5
1.1 Manual purpose.....	5
1.2 To operator.....	5
1.2.1 Primary contents.....	5
1.2.2 Supplements and other information.....	6
1.3 Agreement.....	6
1.3.1 Warning.....	6
1.3.2 Printing and creation agreement.....	7
1.4 Environmental protection.....	7
1.5 Machine label.....	7
1.6 Additional help and information.....	8
2 Safety instructions.....	9
2.1 Standards and instructions.....	9
2.2 Safety regulations.....	9
2.2.1 General safety instructions.....	9
2.2.2 Manual guidance.....	10
2.2.3 Marks and instructions on the machine.....	10
2.2.4 Alteration.....	11
2.2.5 Guarantee.....	12
2.2.6 Safety-transport.....	12
2.2.7 Safety - installation.....	12
2.2.8 Safety-operation.....	12
2.2.9 Safety-maintenance.....	13
2.2.10 Safety - repair.....	13
2.3 Operating skill.....	14
2.3.1 Operator.....	14
2.4 Safety features.....	15
2.4.1 Security function overview.....	15
2.4.2 Emergency stop button.....	16
2.4.3 Film carriage bottom safety device.....	16
2.4.4 Ground lead.....	16

2.5	Main operational risk safety warning.....	16
3	Technical parameter description.....	19
3.1	Main component composition.....	19
3.2	Control panel.....	20
3.2.1	Main control panel.....	20
3.2.2	Sensor location.....	21
3.3	Working principle.....	21
3.4	Optional configuration.....	22
3.5	Technical parameters and main configuration.....	22
3.5.1	Institutional parameters.....	22
3.5.2	Electrical parameters.....	24
3.5.3	Working environment parameters.....	24
4	Transportation and installation instructions.....	25
4.1	Security transport.....	25
4.2	On-site transportation.....	25
4.3	Temporary storage.....	26
4.4	Preparation before installation.....	27
4.4.1	Preparation area.....	27
4.4.2	Ground confirmation.....	28
4.4.3	Electrical confirmation.....	28
4.4.4	Equipment, tools and personnel requirements.....	28
4.4.5	Loading and unloading.....	29
4.4.6	General hardware fastening torque reference.....	29
4.4.7	Installation and service conditions.....	29
4.5	Equipment installation.....	29
4.5.1	Equipment installation preparation.....	29
4.5.2	Column installation.....	30
4.5.3	Film Carriage installation.....	32
4.5.4	Broken film and blocking installation.....	35
4.5.4	Column door installation.....	38
5	Operating instructions.....	39
5.1	Safety instructions.....	39
5.2	The task of the operator.....	40
5.3	Start the machine.....	40

5.4	Install and replace wrapping film.....	40
5.5	Place pallet instructions.....	42
5.6	First put film operation.....	42
5.7	Turn on the equipment.....	43
5.8	Turn off the equipment.....	44
5.9	Touch screen homepage.....	44
5.10	Pause packaging (normal stop).....	46
5.11	Stop in automatic mode (emergency stop).....	47
5.12	Reset to the origin position.....	48
5.13	Select packaging mode.....	48
5.14	Manual operation.....	50
5.15	Setting overview.....	51
6	Maintenance and repair instructions.....	52
6.1	Safety instructions.....	52
6.2	Maintenance preparation.....	52
6.3	End maintenance check.....	53
6.4	Maintenance schedule.....	53
6.5	Check the function of safety facilities.....	53
6.6	Cleaning machine.....	54
6.7	Clean the roller on the film carriage.....	54
6.8	Lubricate film carriage bottom drive chain.....	55
6.9	Lubricate film carriage bottom drive chain.....	55
6.10	Lubricate the belt bearing seat.....	56
6.11	Lubricate the turntable drive chain.....	57
6.12	Check the chain tension of the turntable drive chain.....	58
7	Trouble shooting instructions.....	58
7.1	Safety precautions.....	59
7.2	Troubleshoot.....	59
7.2.1	Touch screen (HMI) alarm condition description.....	59
7.2.2	Description of inverter alarm.....	61
7.2.3	Mechanical common faults and elimination.....	65
8	Appendix.....	67
8.1	Electrical principle drawing.....	67
8.2	Component breakdown diagram and detailed list.....	73

8.2.1 Turntable decomposition diagram and schedule.....	73
8.2.2 Column exploded view and detail list.....	77
8.2.3 Film carriage exploded view and detail list.....	79
8.2.4 Clamping and cutting film exploded view and schedule.....	85
8.3 Spare and wearing parts.....	88

1 Basic Information

1.1 Manual purpose

This manual is intended for training professional users and operators. With the help of this manual, you will be familiar with the pallet wrapping machine and its optional functions, enabling you to use, operate, manage and maintain the machine in a safe and effective manner.

User notice:

- The user must operate the machine in accordance with all safety instructions and procedures and all safety procedures in the work area in this manual ;
- To ensure that the machine is properly installed, debugged, operated and maintained, these operations can only be performed by fully and appropriately trained personnel;
- Ensure that the use of the machine is in full compliance with laws and regulations which have the force of law.

1.2 To operator

This manual is part of the equipment. This information helps machines operate safely and efficiently.



Notice:

Please read this manual thoroughly before operating the machine or executing any procedure.

1.2.1 Primary contents

The source language of this manual is Chinese. The source Chinese text will be legally binding to prevent any discrepancy between the other translated text and the source text.



Notice:

As we continue to improve and develop our products, it is not always possible to provide real pictures of every detail of the machine. Therefore, the illustrations always show a typical standard machine.

1.2.2 Supplements and other information

This manual has been carefully written based on our experience and the latest knowledge. Therefore, the information in this manual is valid and correct at the time of publication (see cover).

As we continue to improve and develop our products, modifications to the machine are part of the internal process. This means that you may receive supplements and other information later, including corrections or improvements.



Notice:

Add these supplements to this manual to ensure that the customer always has the latest version of the manual.

1.3 Agreement

This user manual uses the following agreement

1.3.1 Warning

This user manual lists the following warnings:



Warning

It indicates a risk of personal injury or even death.



Warning

It marks the risk of malfunction or damage to the machine.

Notice

Used to highlight some information.

1.3.2 Printing and creation agreement

- There is always a bullet between lists and enumerations that do not have a specified order.
- It must be performed in the order specified by the number in the process.
- Abbreviations are defined when the manual is first used (except in the title)

1.4 Environmental protection

Please comply with the disposal of used or replaced parts and materials described in this document. All recycling should be in accordance with local environmental laws and regulations.

1.5 Machine label

SMART WASP		Serial No.: XXXXXXXXXXXXX	
Suzhou JiaJun Auto-well Industrial automation Co.,LTD			
Name	Model	Version	Date
<input type="text"/>	<input type="text"/>	<input type="text"/>	<input type="text"/>
Voltage	Phase	HZ	Machine Size
<input type="text"/>	<input type="text"/>	<input type="text"/>	<input type="text"/>
Total Power	Max Load	Weight	Control Model
<input type="text"/>	<input type="text"/>	<input type="text"/>	<input type="text"/>
(PSI T BAR)		Air Requirement (CFM I /min)	
<input type="text"/>		<input type="text"/>	
<input type="text"/>	KA	SCCR	Max V
<input type="text"/>		<input type="text"/>	
Original			
Shanghai	<input type="checkbox"/>	Shenzhen	<input type="checkbox"/>
Suzhou	<input checked="" type="checkbox"/>	Beijing	<input type="checkbox"/>

1.6 Additional help and information

Smart Wasp is committed to providing the highest level of support to its users and operators. Depending on the product, the support provided mainly includes:

- Training
- Service management system
- 24-hour global support
- Maintenance agreement
- Tool service
- Repair and update

For more information, please contact your dealer.

2 Safety instructions

2.1 Standards and instructions

The machine is designed and manufactured in accordance with the requirements of the Machinery Directive 2006/42 / EC and meets the legal requirements applicable on the date of construction:

- Mechanical instruction: 2006/42/EC
- Low voltage directive: 2014/35 / EC
- EMC Directive: 2004/30 / EC

The machine is designed with safety in mind and includes protection against injury and damage. However, all powerful machines can be dangerous if not used properly.

2.2 Safety regulations

2.2.1 General safety instructions

·The tasks described in this manual apply only to appropriately trained personnel with the required skill level (see section 2.3) who are familiar with all safety instructions and regulations mentioned in this manual.

·We are not responsible for any damage or personal injury caused by failure to comply with the safety instructions in this document or the warnings, caution and care described in this manual.

·Other security instructions may also apply, depending on the specific environment in your workspace. Since we have no direct control over these specific working conditions, it is the user's responsibility to ensure compliance with local environmental and safety regulations. If you encounter an unknown security situation not described in this manual, please inform us immediately.

The machine may also contain third-party components. Please refer to the appropriate manual for specific security instructions for these third-party components.

·Please ensure that children and other unauthorized persons cannot enter the work area.

- Please ensure that the working area has adequate light and ventilation.
- Dressed correctly. Do not wear loose clothing. Remove jewelry, watches, etc. to prevent them from getting stuck in moving parts.
- Please wear protective equipment (e.g. protective clothing, protective shoes, gloves, helmet, goggles, earmuffs) according to the user's operating environment.
- Before performing any tasks on the machine, check that the machine is safe and clean.
- Always be vigilant and pay attention to your own operations. Do not work on the machine when you are tired or have drunk or have taken medicine.
- Do not change the structure of the machine. See section 2.2.5.
- Do not open the power distribution cabinet unless authorized.
- Do not graft unless you are authorized to temporarily disable the security features of the machine.

2.2.2 Manual guidance

- Please keep this instruction manual in a safe place near the machine. Ensure that the manual is always accessible.
- Please read this instruction manual thoroughly before using the machine or performing any of the tasks described. Be sure to always have the latest version of this instruction manual.
- Perform the steps in the order given. Do not change the order of the steps.

2.2.3 Marks and instructions on the machine

- Marks or instructions on the machine are part of the security feature. They must not be covered or removed and must be clearly visible throughout the life of the machine.
- Damaged or illegible signs and instructions must be replaced or repaired immediately.

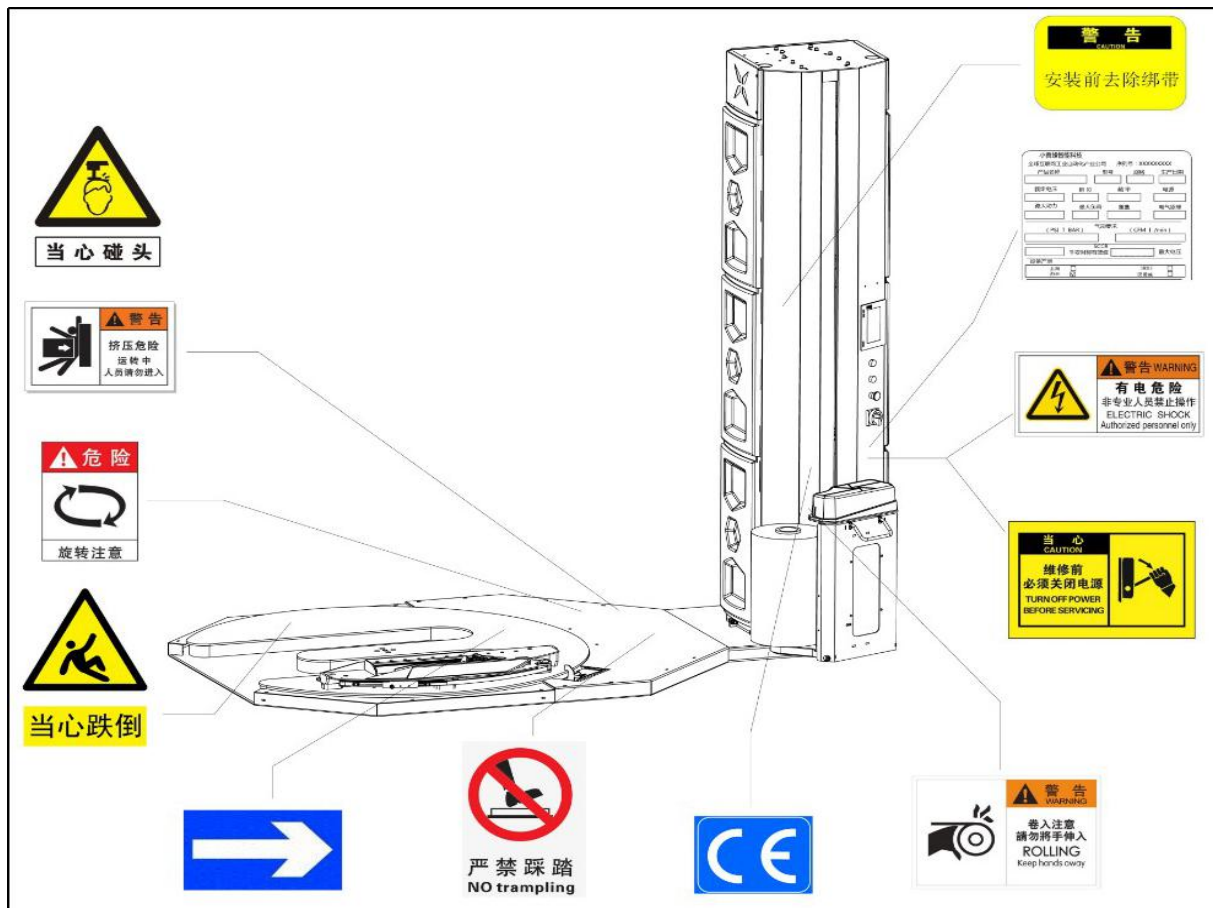

- A Warning: Be careful with head injuries
- B Warning: Squeeze danger, do not enter the machine during operation.
- C Danger: Pay attention to danger when the turntable rotates
- D Warning: Beware of falling near the turntable
- E Warning: Remove the strap before installation
- F Instruction: Label of machine
- G Warning: Non-professional personnel are not allowed to operate the electric cabinet, there is electrical danger
- H Warning: Power must be turned off before repair
- I Warning: please do not put your hand into the roller of film carriage
- J Instruction: CE
- K Warning: Do not stand on the turntable
- L Indication: the rotational direction of the turntable

2.2.4 Alteration

Warning

Do not attempt to make any modifications or changes to the machine or program without the prior

express consent of Smart Wasp. Unauthorized modifications or alterations to the machine may result in serious personal injury or death.

Smart Wasp is always willing to discuss improving the value of the machine by modifying it for the user. See section 1.6

2.2.5 Guarantee

•The machine is warranted for 12 months after installation. To exclude components and electrical components that may wear out during normal use, the customer must notify the dealer of the defect and the machine serial number. The customer must be able to hand over the defective component to the dealer. The dealer will resolve the defect within a reasonable time.

When problem must be resolved at the customer's location, the customer bears the additional cost. The extra cost is for labor, travel or accommodation.

•The dealer is not responsible for any accidents or delays in the production process. When the customer adjusts the machine with components that are not recommended by the dealer, the dealer cannot guarantee that the machine meets the EC requirements.

2.2.6 Safety-transport



Notice

Usually the machine is shipped by dealer or with the help of instructions provided by the dealer. When relocating the machine, please observe the safety instructions provided in Chapter 4.

2.2.7 Safety - installation

Notice



Usually the machine is installed and adjusted by the dealer or with the help of the instructions provided by the dealer. When relocating the machine, please observe the safety instructions provided in Chapter 5.

2.2.8 Safety-operation

Please follow the general safety instructions. See section 2.2.1

- Make sure the machine and its vicinity are kept dry.
- Keep away from moving parts
- Do not stand on the turntable even if the machine is turned off.
- Do not touch the area between the turntable and the machine floor (Be careful of finger crush)

When the machine is running:

- Please do not touch the turntable.
- Keep away from the area between the pallet.
- Do not try to manually stop or drag the tray, please use the emergency stop button
- Please wear personal protective equipment as specified or recommended by the user.
- The film carriage moves up and down during operation. Keep away from the the plate slide (to prevent finger crush or foot injury).

2.2.9 Safety-maintenance

- Please follow the general safety instructions. See section 2.2.1
- Before starting any maintenance (even cleaning):
 - Put the switch button in the "OFF" position
 - Remove the power plug
 - Wait at least two minutes
- Do not wash the machine with water (electric shock hazard)
- Do not use solvent cleaning machine. Only use dry cloth and neutral cleaner to clean the machine.
- If the security feature is temporarily disabled, the security feature is reactivated or enabled as soon as the maintenance work is completed. After cleaning the machine, please make sure to check the normal function of the safety function before production.
- Do not leave anything inside or on the machine.
- The sensor's detection range has been set by the manufacturer. Do not change the setting.

2.2.10 Safety - repair

- Please follow the general safety instructions. See section 2.2.1
- Before starting any repair:
 - Put the switch button in the "OFF" position
 - Remove the power plug
 - Wait at least two minutes
- If the security feature is temporarily disabled, the security feature is reactivated or enabled as soon as the maintenance work is completed. After cleaning the machine, please make sure to check the normal function of the safety function before production.
- Do not leave anything inside or on the machine.

2.3 Operating skill

2.3.1 Operator

- Only licensed operators are allowed to work on the machine.
- All operators can only perform their trained, executable operations.
- All operators using the machine must be familiar with the instructions.
- Operators must be familiar with all possible situations so that they can act quickly and effectively in an emergency.
- This machine is only for people over the age of 16. The corresponding national occupational safety and health regulations must be observed.

2.3.2 Operator Skills

Operators are trained to:

- Loading and unloading pallets.
- Use the controls on the control panel and the remote control to control the machine.
- Wrap pallets.
- Prepare to load and unload film rolls.
- Prepare to load and unload film rolls.



Notice

It is the user's responsibility to ensure that the machine operators are adequately trained in their operational tasks before starting work again.

2.4 Safety features

2.4.1 Security function overview

This pallet wrapping machine has the following safety features:

- Emergency stop button (Please see section 2.4.2)
- Safety marks and instructions (Please see section 2.2.3)
- Film carriage bottom safety device (Please see section 2.4.3)
- Ground lead (Please see section 2.4.4)

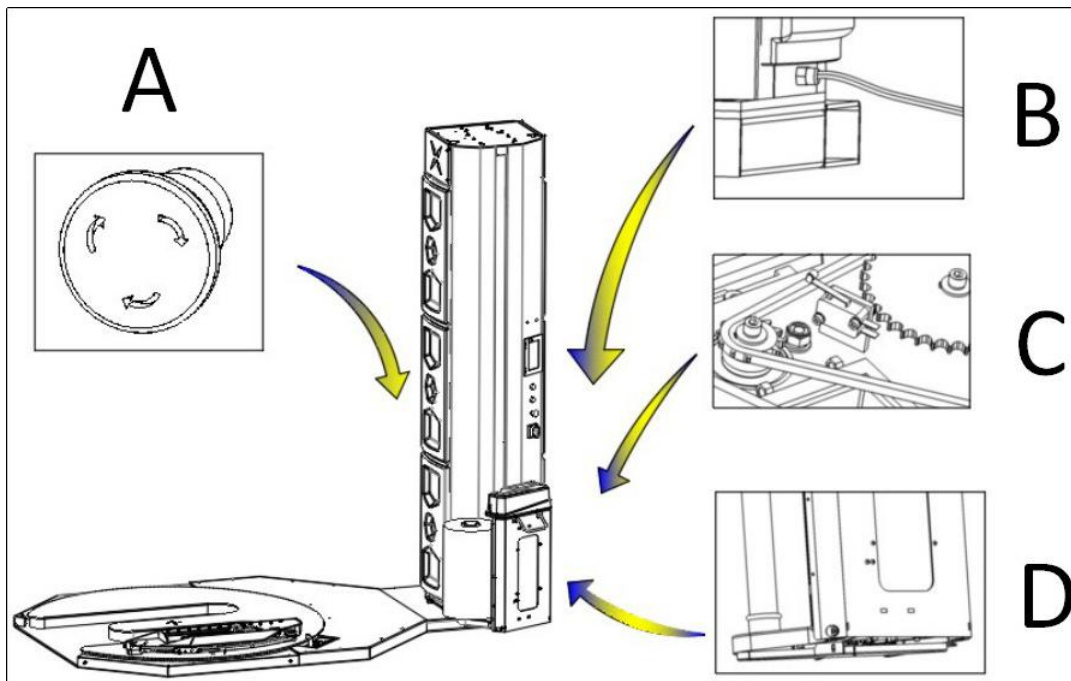

- A Emergency stop button
- B Ground lead
- C and D Film carriage bottom safety device

2.4.2 Emergency stop button

The emergency stop button is in the control panel.

Notice



In case of emergency, press the emergency stop button to stop the machine.

2.4.3 Film carriage bottom safety device

The film carriage bottom anti-drop protection switch is located under the film carriage. The machine will stop once the lower plate touches the protection switch.

2.4.4 Ground lead

The electrical system is grounded. A continuity test has been performed on the ground wire. The electrical system was tested for insulation and dielectric strength at the factory.

2.5 Main operational risk safety warning

Operators must pay attention to the following safety warnings during the normal operation of the equipment.

•Physical collision and hazard:

Do not touch the machine parts while the machine is running.

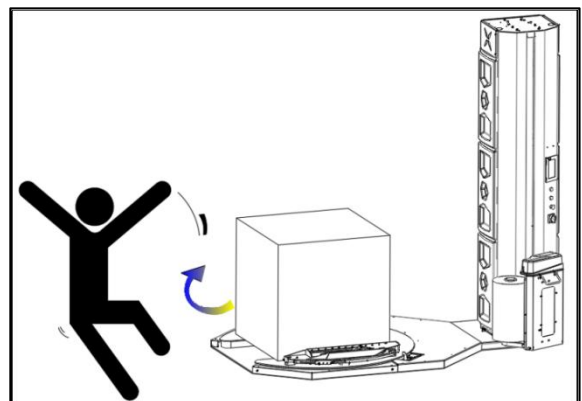

- Keep away from operation area:
Do not stay in the operating area of
the machine



- Risk of collision:
do not stand under the film carriage

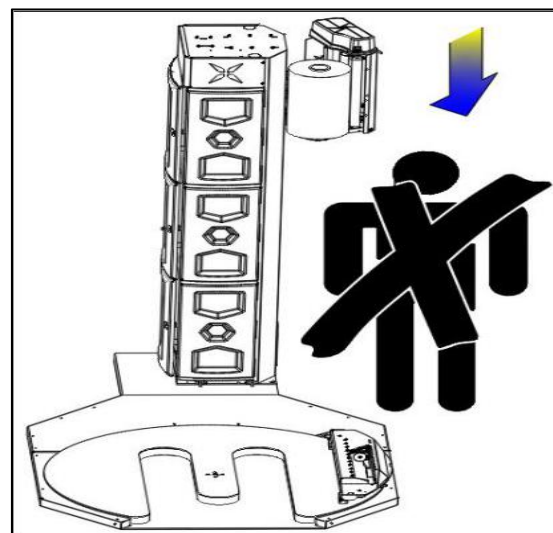

- Risk of collision when starting:
Do not stand disc objects when
starting
Nearby is danger.

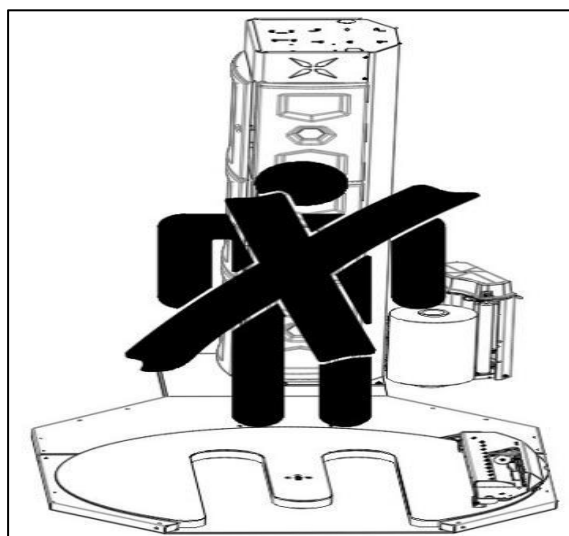

·Other dangerous situations at startup:
When moving goods, the forklift is
far away from the machine cargo

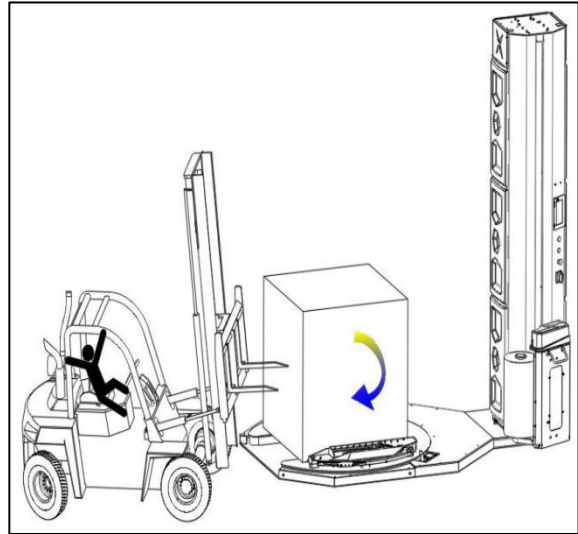

3 Technical parameter description

3.1 Main component composition

X500 pallet wrapping machine adopts special film to package the pallet goods. The film can be uniformly attached to the pallet goods in the pre-pull mode, and its main components are shown in the following figure.

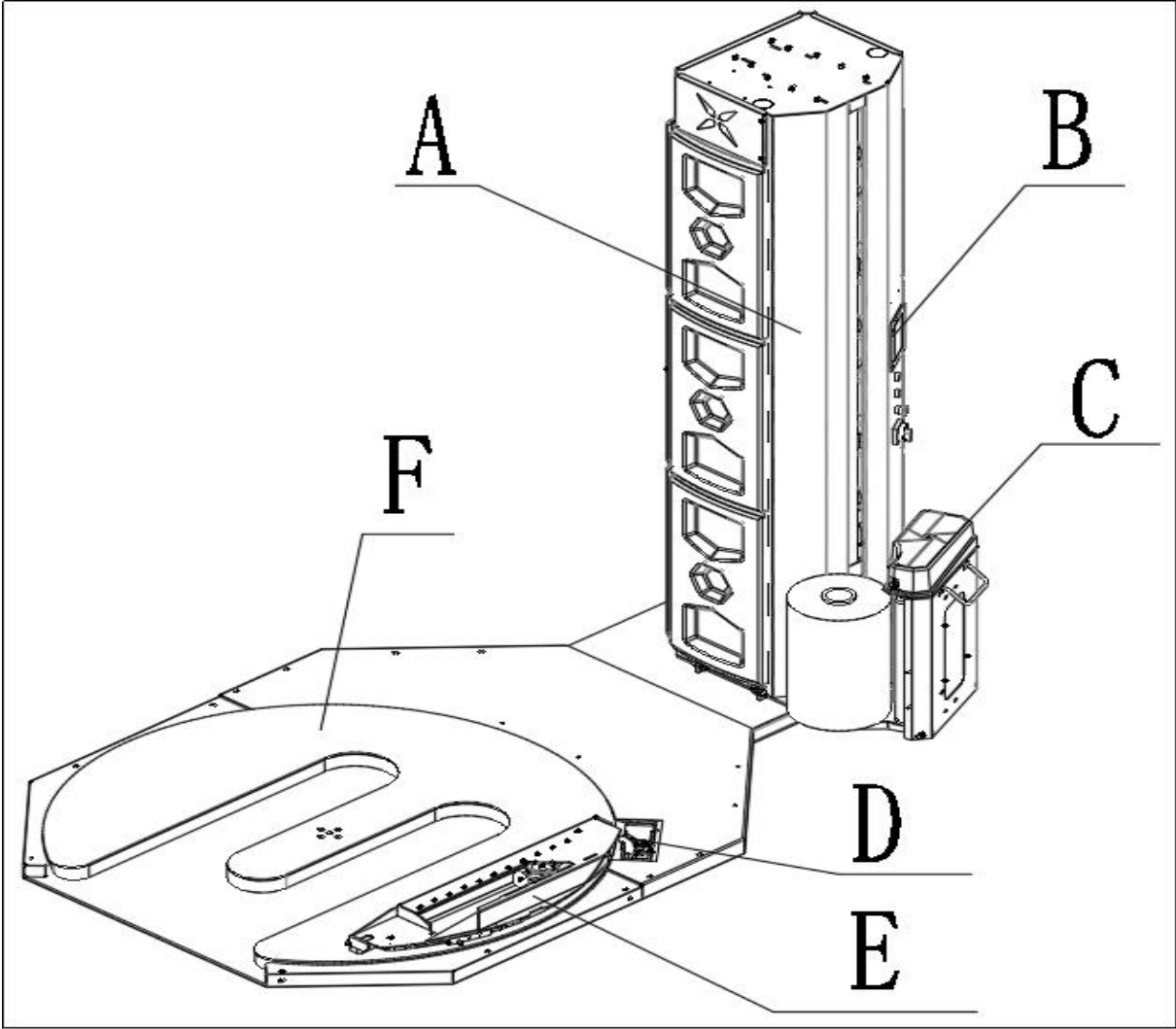

- A Column
- B Touch Screen
- C Film Carriage
- D Turntable
- E Clamping and cutting system

3.2 Control panel

3.2.1 Main control panel

Serial number	Name	Function
TOUCH	Touch Screen	It is used to operate the operation of the device and set the operating parameters. Refer to section 5.7
A	Main power switch	Turn the main switch clockwise to energize the power supply of the equipment. Turn the main switch counterclockwise to turn off the power.
B	Emergency stop switch	Press the emergency stop switch, the equipment will stop running immediately in any state; Turn the button clockwise to release the emergency stop switch.
C	Power indicator	When the main power switch is turned on, the power indicator lights.
D	Start button	Operate the start button and the machine starts to run automatically.

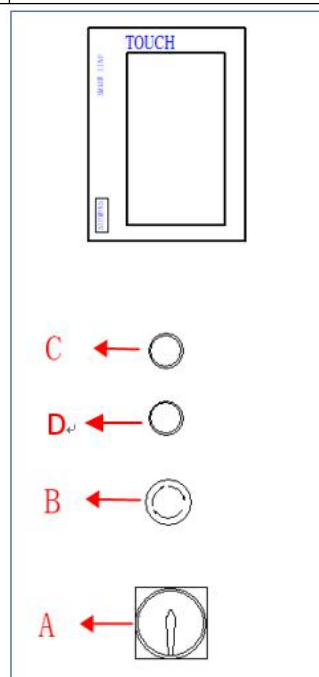

3.2.2 Sensor location

The following icon shows the location of the device's sensor and the information connected to the system, which is convenient for maintenance.

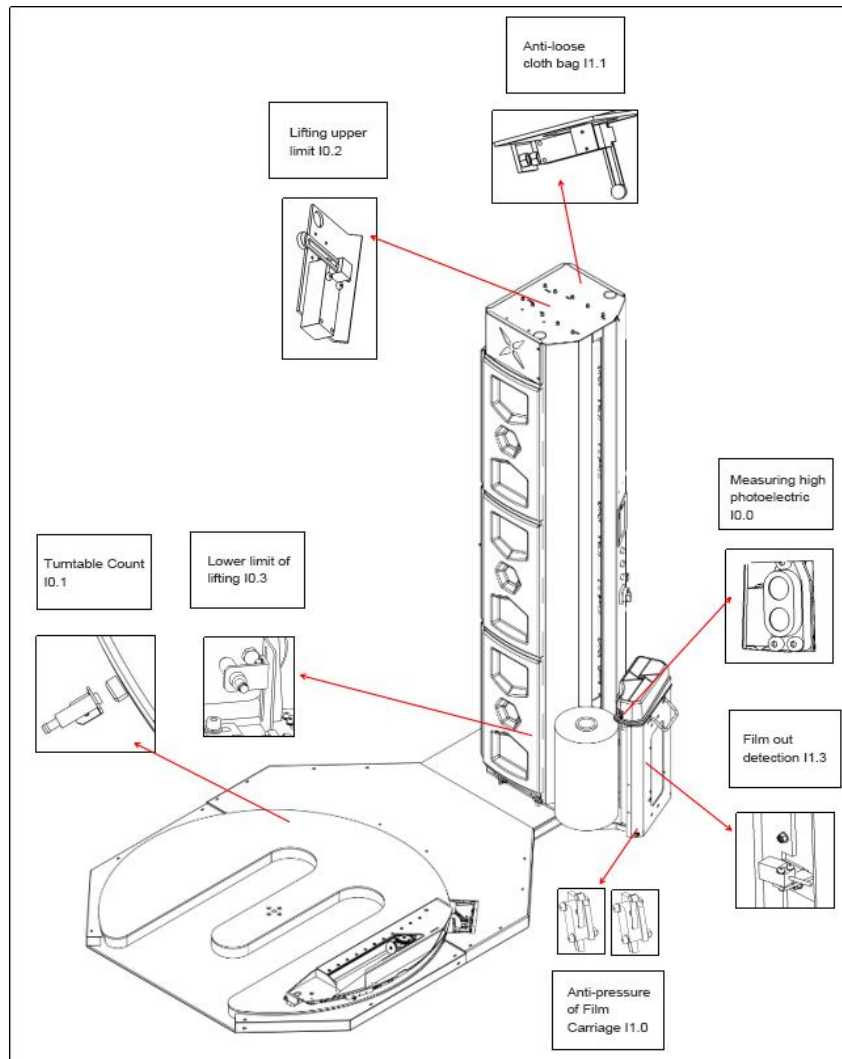

3.3 Working principle

The operation of X500 standard winding machine can be completed by one operator. Its basic working principle is as follows:

1. The goods are transported by forklift to the standard wrapping machine, put on the film roller and the film is manually affixed to the first surface of the goods (See 5 operating instructions for details).
2. Start the wrapping machine, and the cargo starts to rotate from the initial position

(original position). At the same time, the film carriage cooperates with the speed of the turntable to release the film. The film is wrapped on the cargo under the rotation of the turntable.

3. According to the packaging requirements of different goods, the film begins to rise after winding a certain number of turns at the bottom of the cargo. The rise of the film carriage, the rotation of the turntable and the film release together to achieve the overall packaging of the goods.
4. When the film is wrapped to the top of the cargo, the photoelectric sensor senses the height of the cargo, and the film carriage begins to descend after completing the top winding.
5. When the film carriage moves to the bottom, the turntable starts to decelerate, and under the cooperation of the barrier and/or rope making, the film is cut by the cutting film and the film head is clamped to realize the automatic cutting of the film;
6. After the turntable stops, the top pressure is reset (the cooperation of the film head on the turntable and the film is drawn out to facilitate the next film loading), at this time a packaging cycle is over, the machine is in standby state, waiting for the wrapping and packaging of the next pallet.

3.4 Optional configuration

Pit configuration



Notice

According to the site conditions of different users, the working face of the equipment is parallel to the working face of the turntable, and the pit is used as an option to facilitate the use of specific customers.

3.5 Technical parameters and main configuration

3.5.1 Institutional parameters

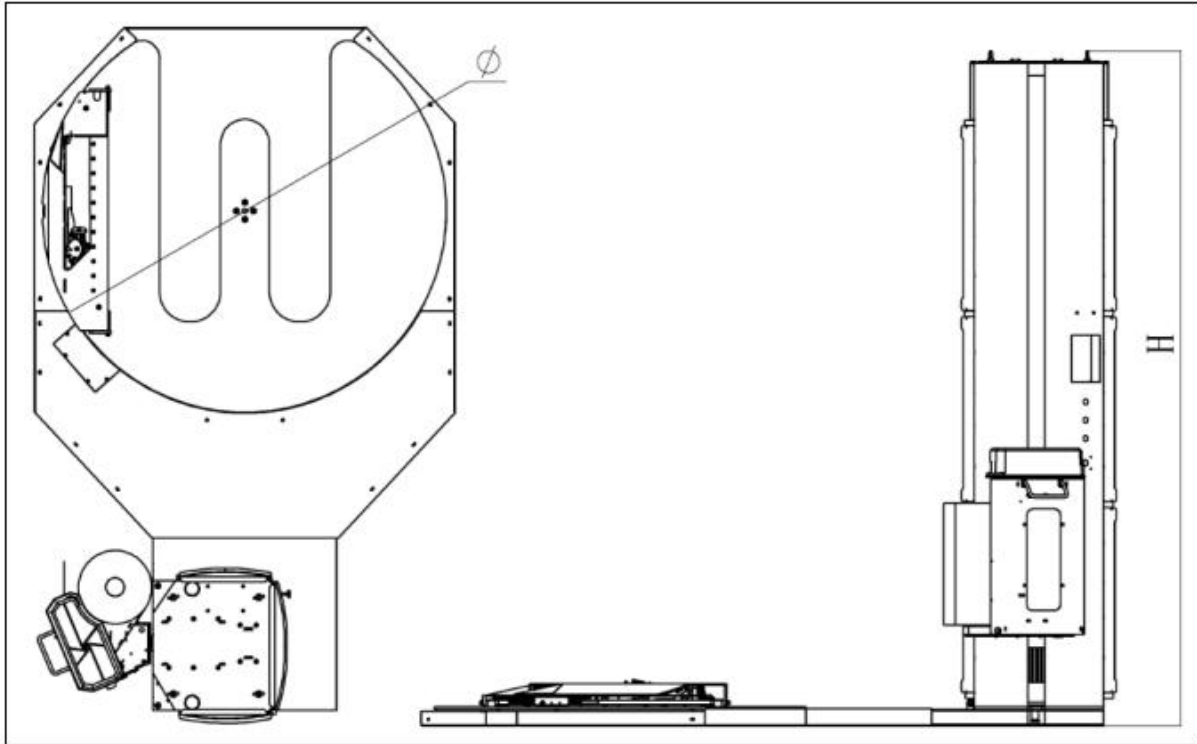

Model	X500	Machine size	See the figure above
Brand	Smart Wasp	Film thickness	14mic
Film width	500mm	Film paper core	250mm
Release film mode	Dynamic pre-stretch	Standard pre-stretch rate	250%
Max packing speed	30~40 pallets/hour	Intelligent sensor	standard
Max wrapping height	2350mm	Max wrapping weight	1500KG
Turntable speed	3-12RPM(adjustable)	Film carriage up&down speed	0-2.6m/min (adjustable)

Turntable	Optional	Automatic cutting film	Have
Machine weight	900Kg	Place film mode	Manual
Weighing scale	Optional	Wrapping force	Adjustable

X500 pallet wrapping machine turntable with existing (Φ) diameter is 1650 mm, 1800 mm and 2000 mm, the form shown in column and package of the existing high configuration:

Column (mm)	Wrapping height (mm)	Total height (H: mm)
2400	2000	2700
2650	2250	2950
3200	2800	3500

3.5.2 Electrical parameters

Machine voltage	220V-240V/50/60Hz Single-phase	Total power	1.5KW
PLC	Siemens	Touch screen	Siemens
Motor	SMARTWASP	Inverter	Siemens
Contactator	Siemens	Sensor	Germany SICK

3.5.3 Working environment parameters

Temperature range	0°~ +40°	Humidity range	≤70%(relative humidity)
Noise	70dB	Pneumatic environment	No

4 Transportation and installation instructions

4.1 Security transport



Notice

- 1. Please note that for the transport of machines must follow general safety practices and the safety instructions given in this section.*
- 2. The packaging material is composed of plastic film, three-ply, etc. (please follow the local advice or regulations on disposal and recycling of packaging materials)*
- 3. Pay attention to waterproofing and violent vibration during transportation.*

4.2 On-site transportation



Notice

There is no need to disassemble the machine, the machine can be moved as a whole.

1. 1、 Turn on the power and move the film carriage up a distance(See the operation instructions section 5 for details)
 - a. Turn on the machine
 - b. Click on the touch screen to input the password to enter the main interface.
 - c. Select manual mode
 - d. Click on the film carriage to rise, rise to the suitable height and stop

Turn the main power switch counterclockwise to turn off the machine

2. Press the emergency stop button Remove the power plug from the power socket

Insert the forks of the forklift into the bottom of the machine and raise the machine about 50mm, as shown in the figure below

Move to a new place

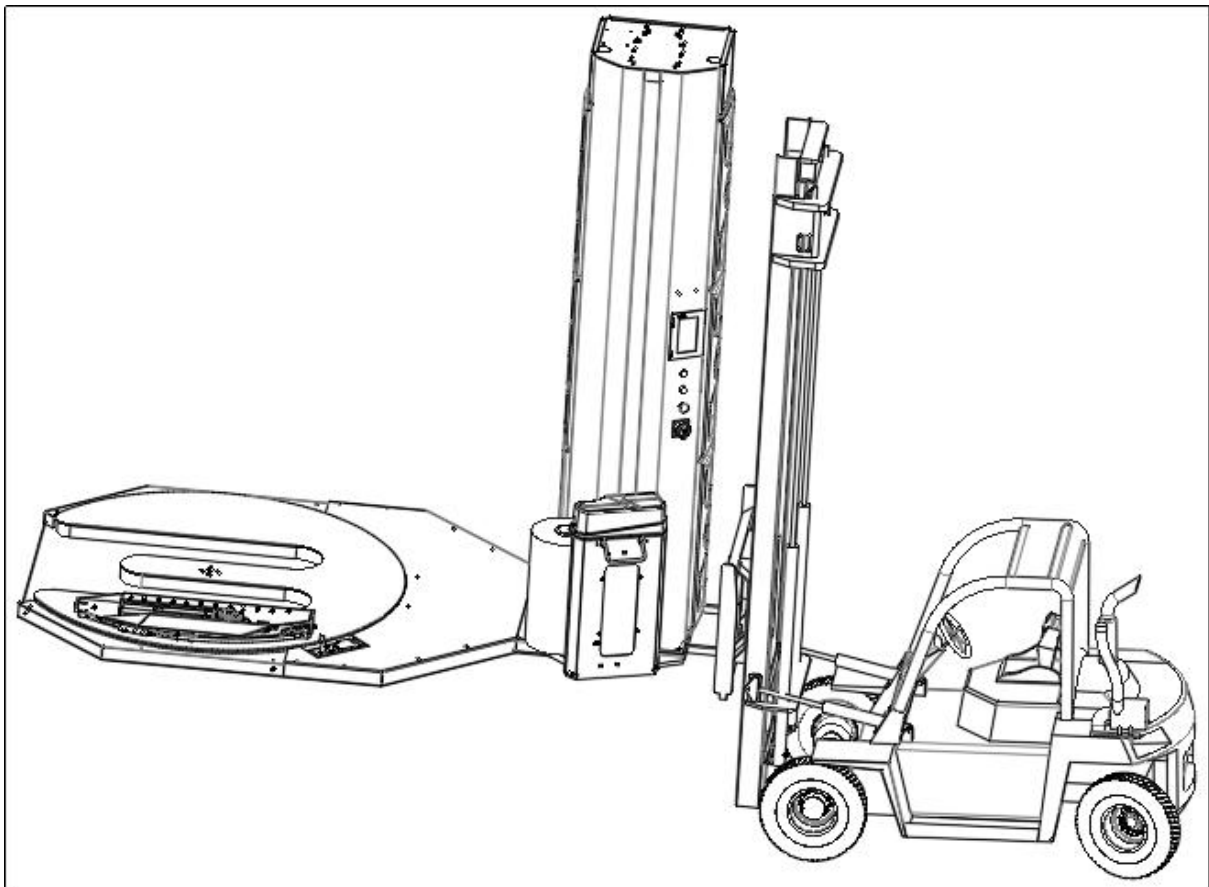

Notice

During transportation, pay attention to obstacles on the top of the machine and obstacles on the floor, such as sinks.

4.3 Temporary storage

If the machine must be stored temporarily, please follow the steps below.

1. Protect the machine from dust
2. Store the machine in a clean, dry place. The environmental conditions required for installation also apply to storage.
3. Please don't put anything at the top of the machine.

4.4 Preparation before installation

Please read the entire installation section before you start, then follow the instructions to install it step by step.



Notice

(1) Finish each step before moving on to the next!

(2) The device has multiple security measures. Operating in the right way will ensure safe operation. Please observe all safety signs. Do not turn on the power before completing the installation.

4.4.1 Preparation area

The installation area of this machine must meet the following space

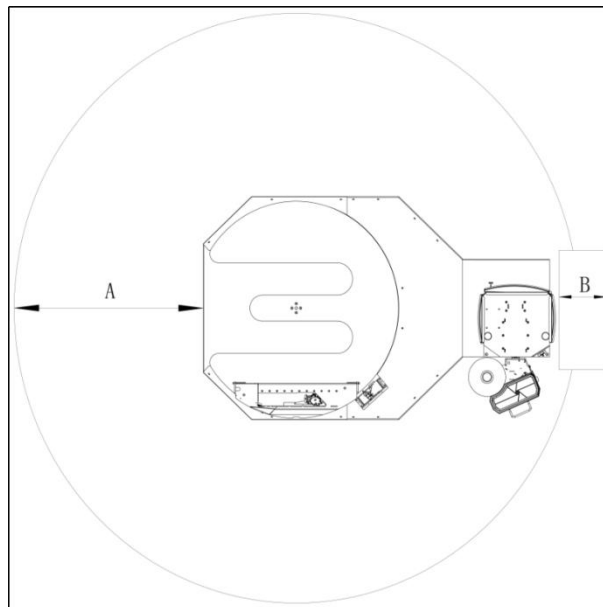

A 2000mm

B 1000mm

- Leave some space around the machine for daily operation, maintenance and repair.
- To get the machine running at its best, place the machine on a flat surface. If necessary, level the machine with a gasket.

4.4.2 Ground confirmation

The ground must be able to withstand the weight of the equipment, the maximum load of the equipment and its impact, so it is required:

Ground bearing capacity \geq (total weight of equipment + weight of goods) \times 1.5.

4.4.3 Electrical confirmation

The system requires a dedicated single phase grounded power supply

220V/AC; 10A; 50/60Hz; 1PH



Notice

For specific electrical requirements, please refer to the machine identification label or electrical drawings.

Notice



(1) Use of extension cords and any other changes may result in damage to the circuit or affect device performance and may void the warranty. For changes, please call after-sales service.

(2) To avoid damage to the equipment, check the voltage in the electrical drawing before starting the equipment.

4.4.4 Equipment, tools and personnel requirements

- Standard wrapping machine one set
- One set of tools (in the toolbox), one forklift

- 1-2 mechanical/electrical technicians and 1 user

4.4.5 Loading and unloading

(1) Main body (the turntable and its column) Part loading, unloading and handling

Equipment used: forklift.

Method of operation: Use a forklift to remove the equipment and transport it to the installation site.

(2) Other spare parts: Before handling the disassembled main body, other parts and components shall be manually moved.

4.4.6 General hardware fastening torque reference

The torque and performance specifications of the fasteners provided and recommended by this product are shown in Table

Metric fastener torque comparison table		
Nominal size of fastener	Performance level	Torque (Nm)
M6	8.8	14
M8	8.8	24
M10	8.8	54
M12	10.9	102

4.4.7 Installation and service conditions

Humidity \leq 70% Temperature 0-40°C

4.5 Equipment installation

4.5.1 Equipment installation preparation

(1) Move the equipment to the installation area with a forklift, and remove the items used for outer packing, tying materials and fixing equipment.

(2) Take out the attached tools, check whether the equipment is complete and put in order.

(3) Make sure the trolley is locked on the stiffener plate of the support frame, to prevent the lifting body from colliding with the base and damaging the parts during the erection process.

As shown in figure 4.5.1.

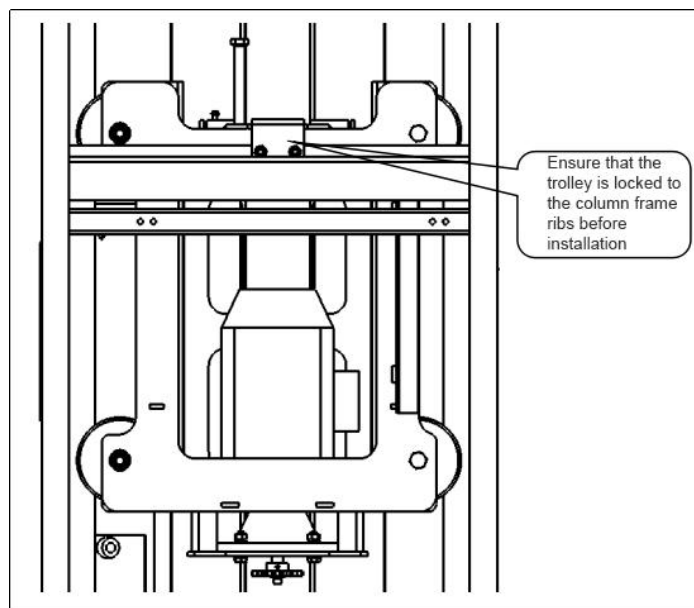

Figure 4.5.1 Locking trolley

4.5.2 Column installation

(1) Raise the column and be careful during operation

Before installation, the surface of the chassis should be placed with soft material base pad, and then erect the column. During the erection process, take care to avoid bumps and impacts between the column and the turntable to prevent damage to the parts. Ensure that the rotating center screw is loose before erecting, ensuring smooth rotation when the column is erected. After erecting the column, lock it to the chassis and then lock the rotating center screw. Note: If the equipment is transported far away or sent overseas, the column and turntable are packaged separately.

(2) Use the attached tools to mount the column to the turntable (see Figure 4.5.2.1 for the installation of the column)

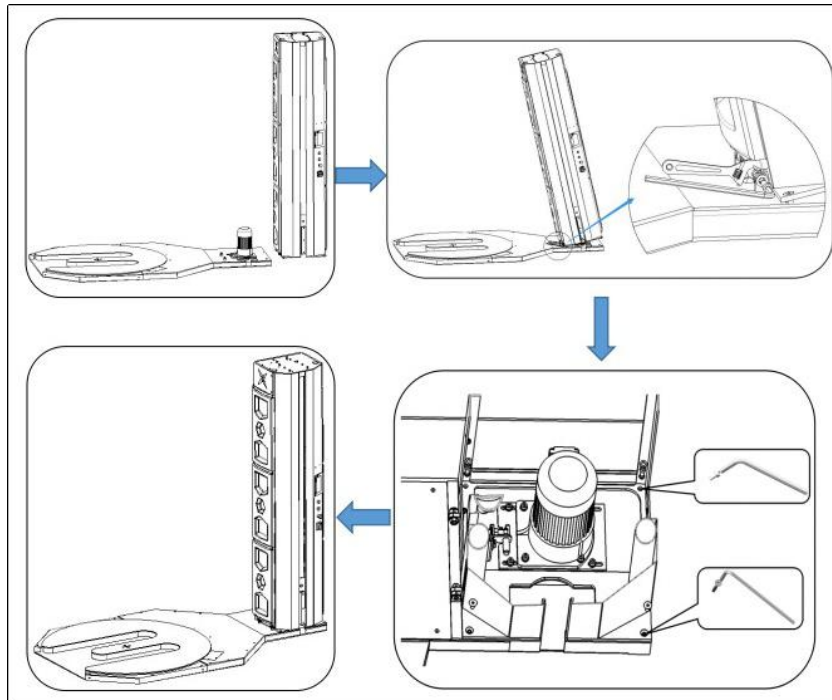

Figure4.5.2.1

(3) Connection between quick plug of power cord of chassis motor and reserved quick plug of column is shown in figure 4.5.2.2.

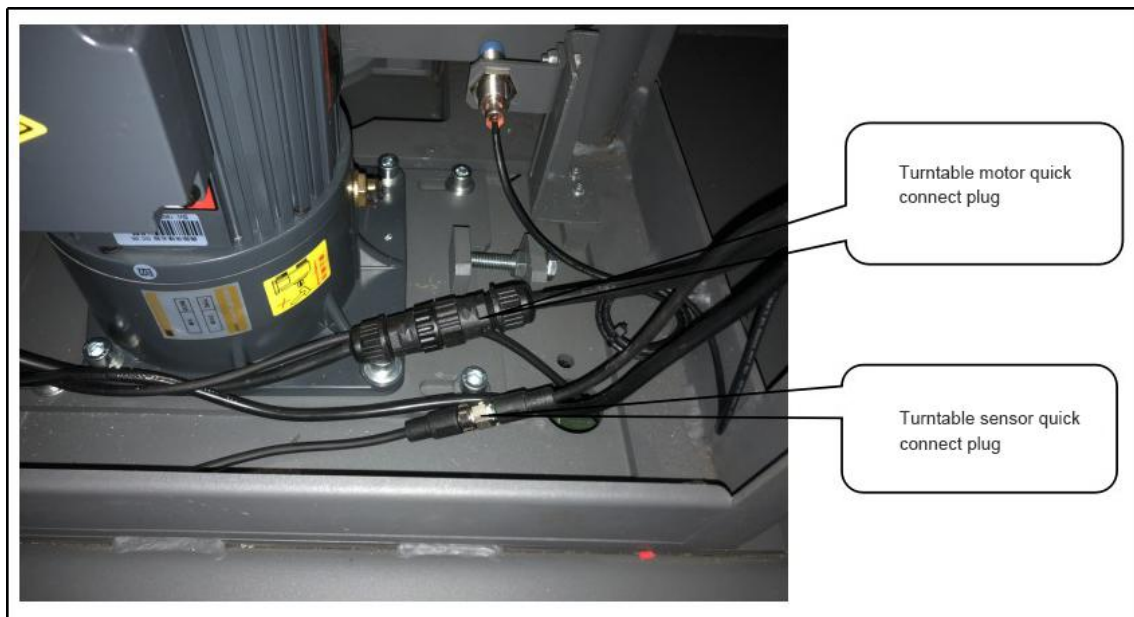

Figure4.5.2.2

4.5.3 Film Carriage installation

(1) Unlock the trolley from the stiffener plate, and check that the cloth belt anti-loosening switch is properly pressed by the cloth belt. As shown in the figure 4.5.3.1 below.

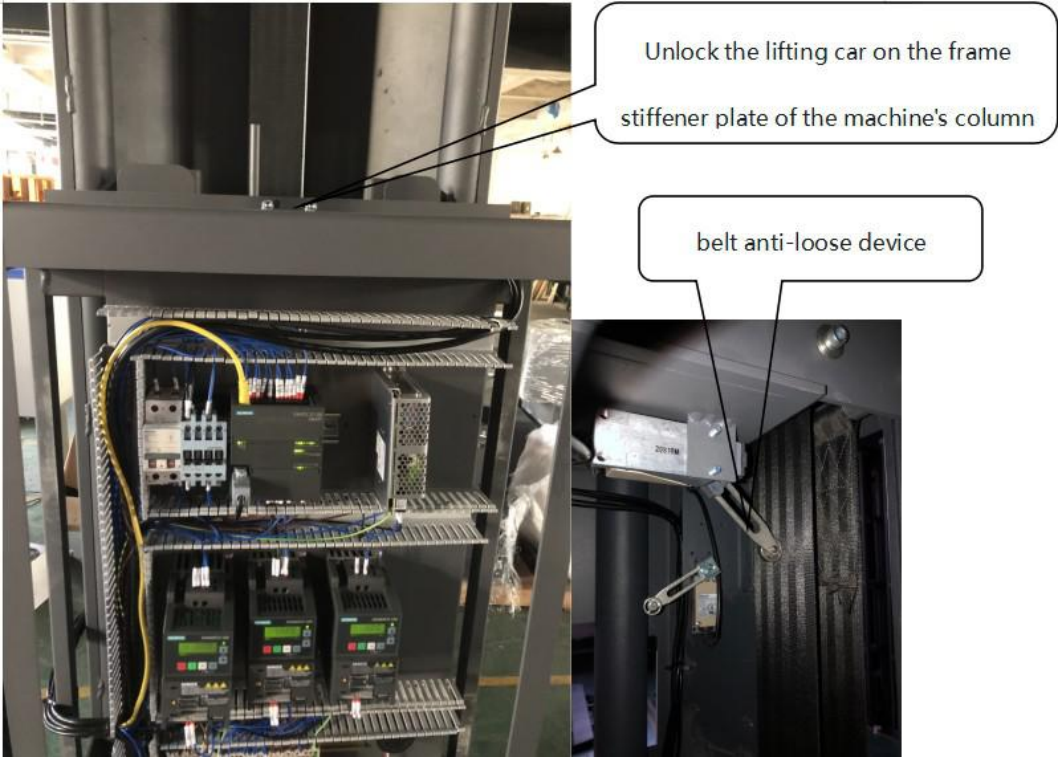

Figure4.5.3.1

(2) Turn on the power and manually reset the cart to the lower limit. Rotate the main power switch to turn off the machine as shown below.

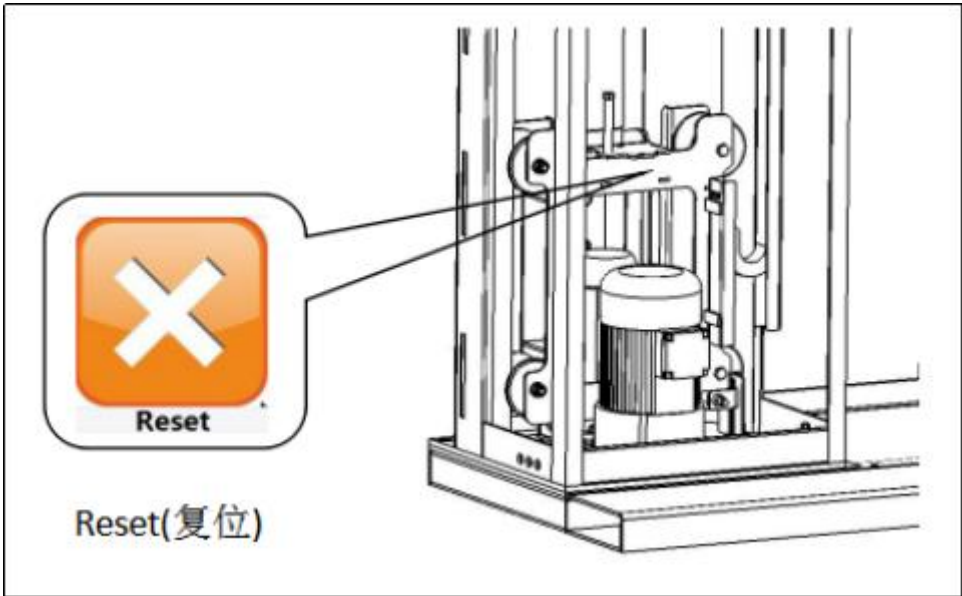

Figure4.5.3.2

Manually hang the film carriage from the outside of the column on the trolley, and pay attention to lead the connecting wire to the lifting body through the threading hole below the hanger plate. Use the corresponding installation bolt to lock the film carriage and the trolley. As shown in the figure below.

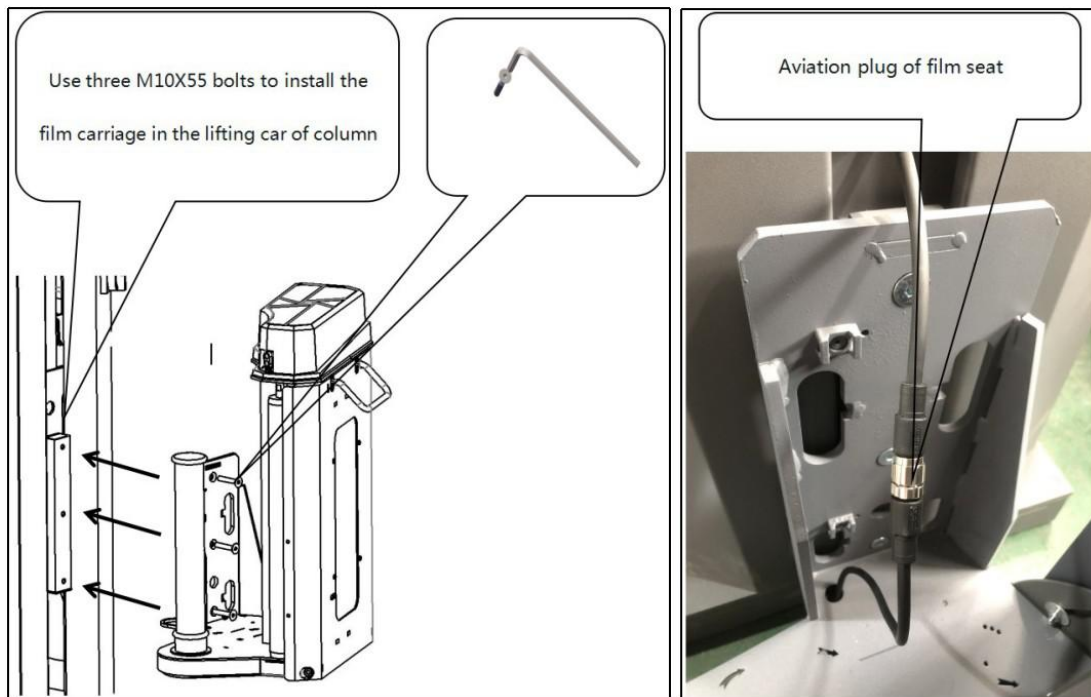
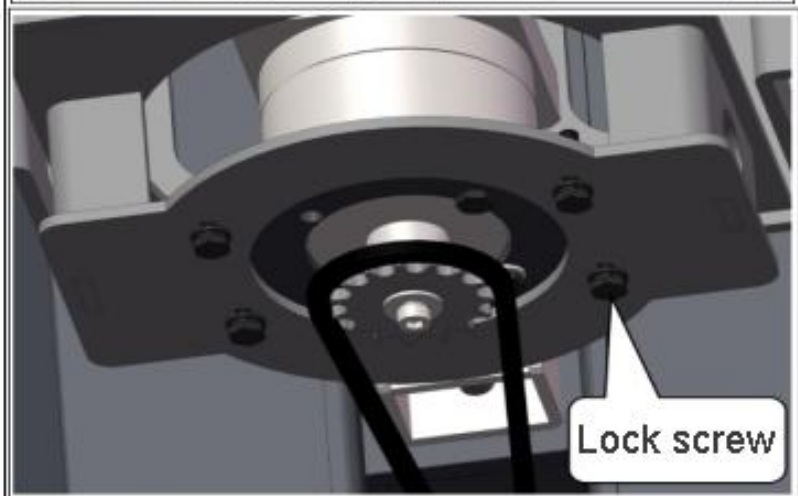
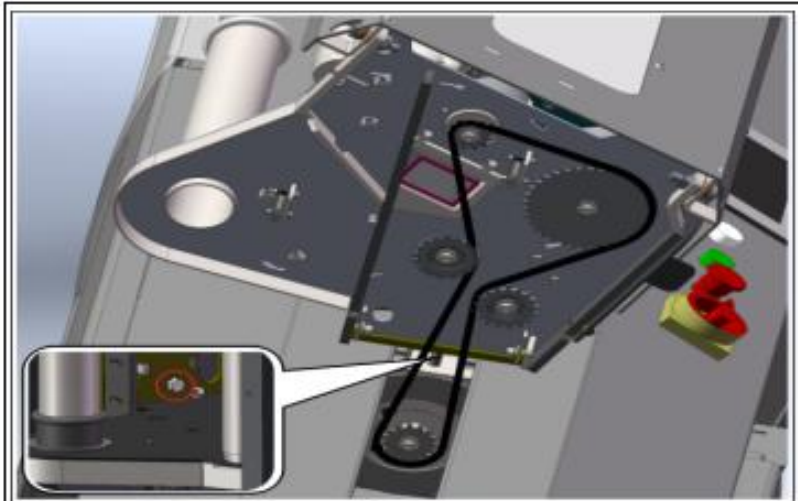

Figure4.

5.3.3

(4) Rotate the main power switch clockwise, raise the film holder to a suitable height with manual mode, rotate the main power switch counterclockwise, and turn off the machine.

(5) **Install the film tensioning sprocket and connect the film seat film tensioning drive chain, as shown in the following series of figures.**



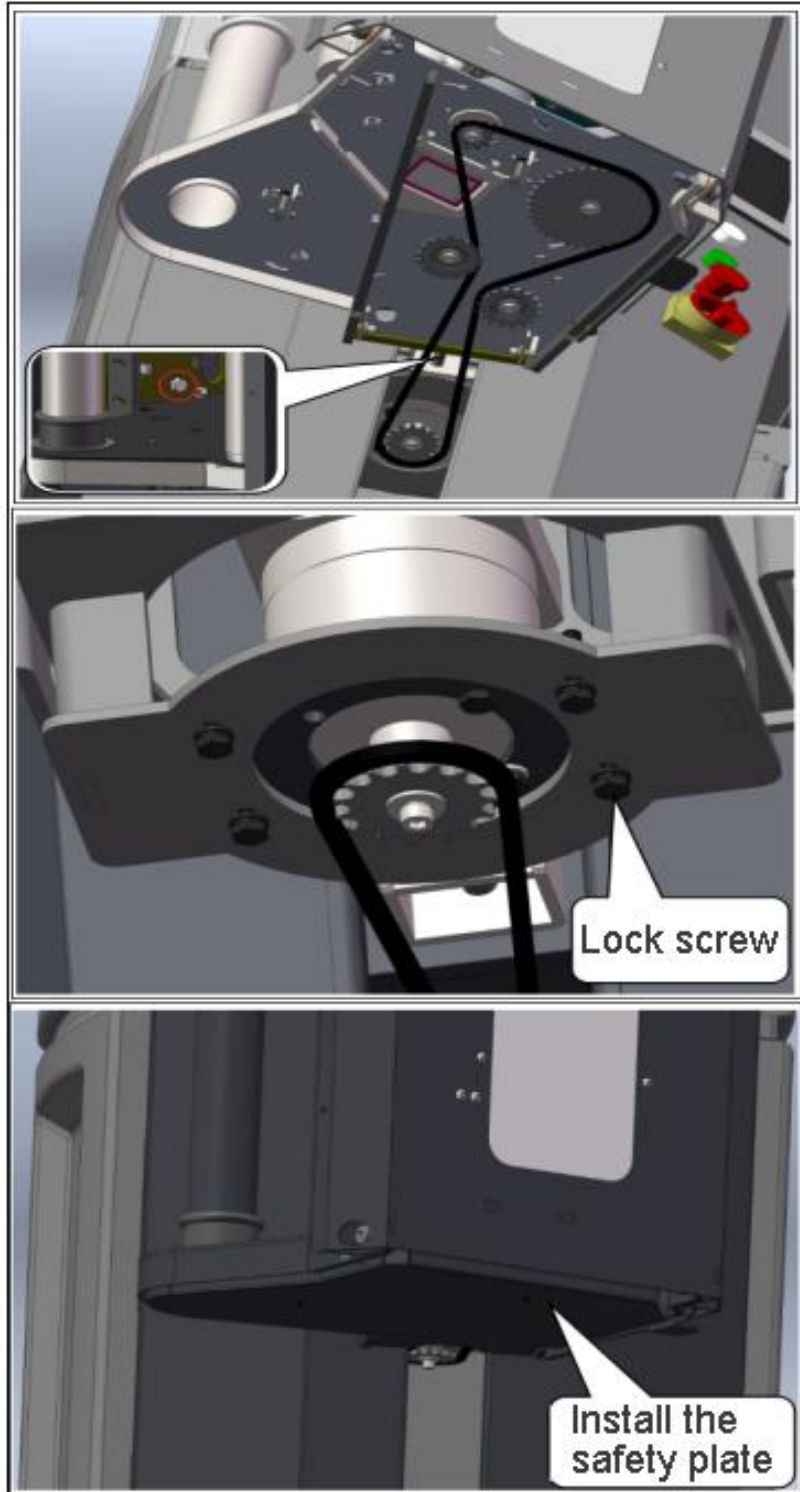

Figure4.5.3.4

(6) Close the membrane seat safety plate and rotate the membrane seat safety plate screw into the elongated hole.

(7) Turn the power on, manually reset the film carriage to the lower limit, then turn off the equipment and disconnect the power.

4.5.4 Broken film and blocking installation

(1) Place the film cutting system vertically on the turntable (be careful to handle it carefully to avoid scratching or damaging parts), align the holes of the film cutting system mounting block with the threaded holes on the turntable, and use M8*25 hexagon socket head screws to break The membrane device is installed and locked on the turntable as shown in Figure 4.5.4.1.

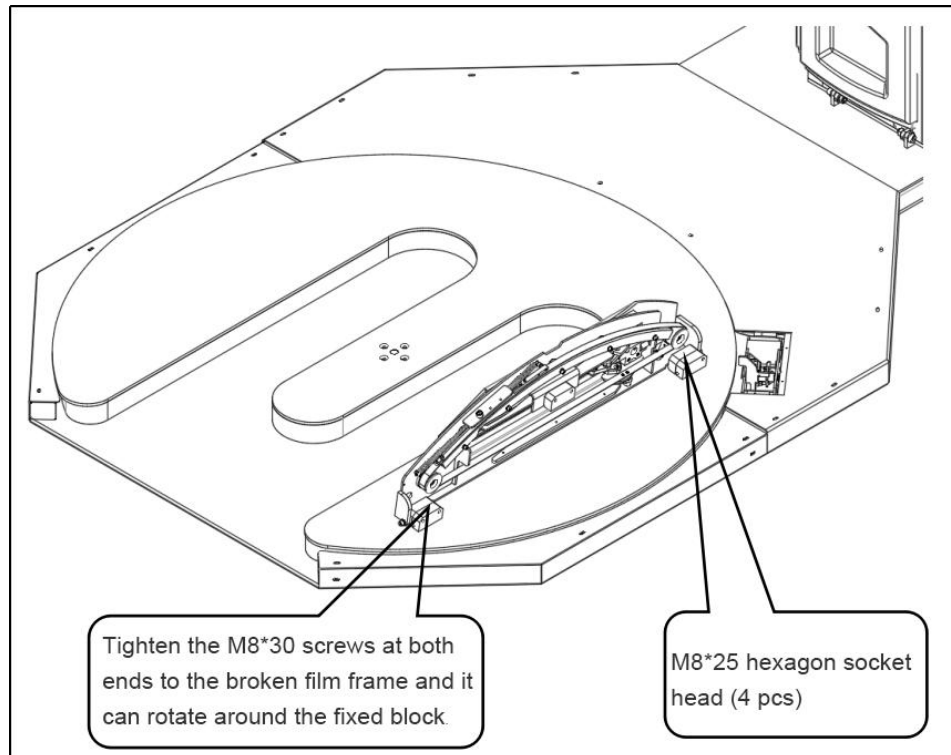

Figure4.5.4.1 Fix film cutting system

(2) Rotate the broken film frame around the fixed block and place it on the surface of the turntable as shown in Figure 4.5.6.2.

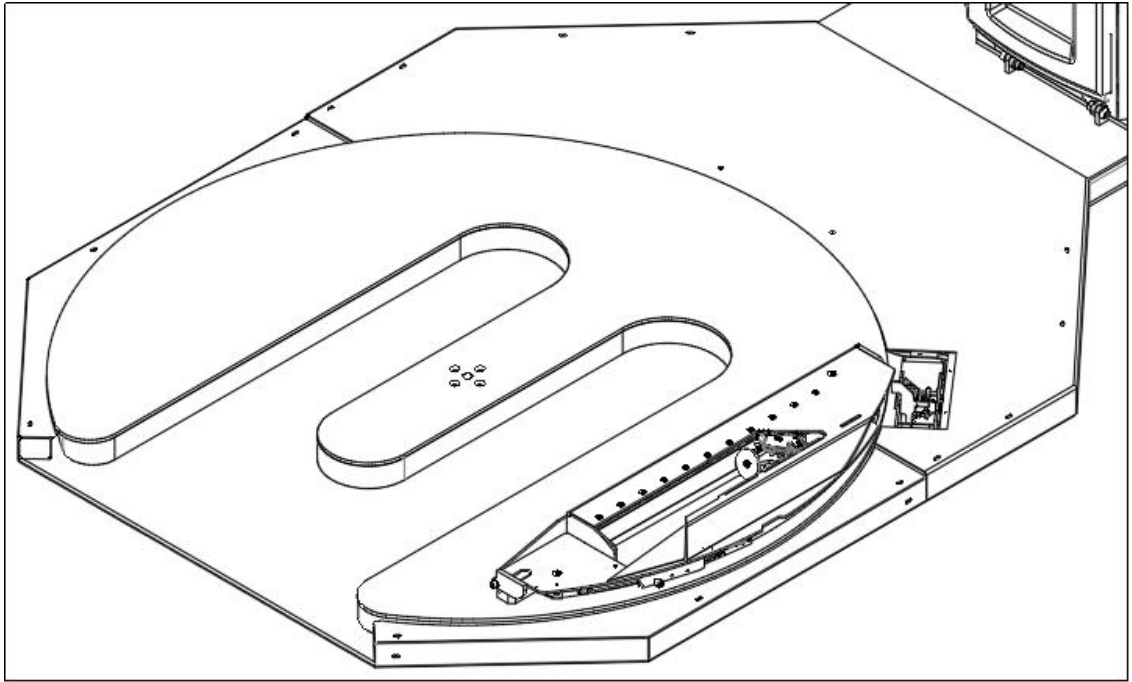

Figure 4.5.4.2 Rest the film cutting system

(3)The mechanism of the stopper has been debugged and installed on the chassis before leaving the factory as shown in Figure

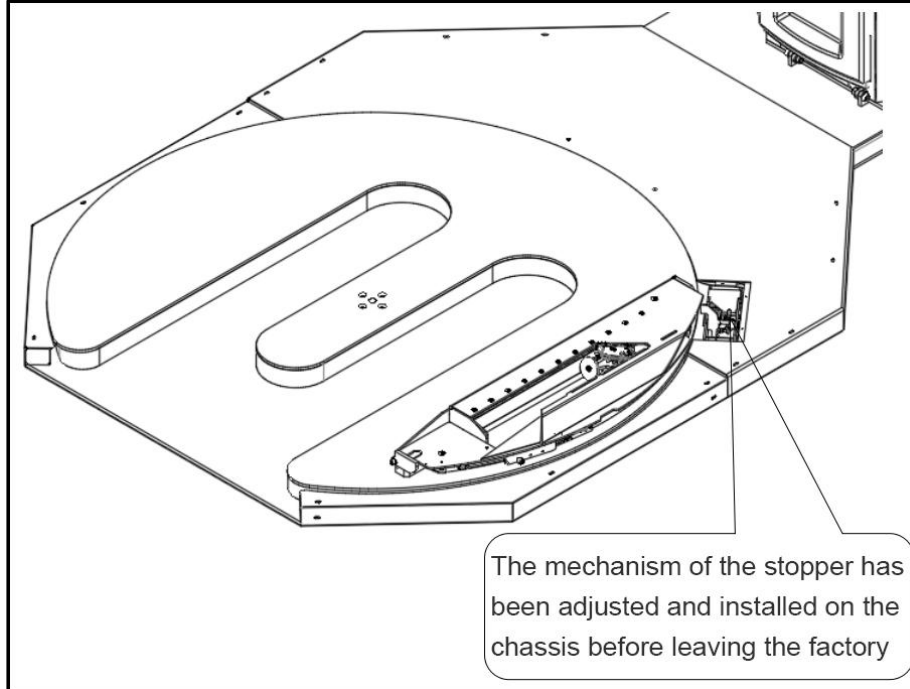

Figure 4.5.4.3 Blocker

4.5.4 Column door installation

Schematic diagram of the column door installation process. Note the installation sequence of the door as shown in figure 4.5.4.1

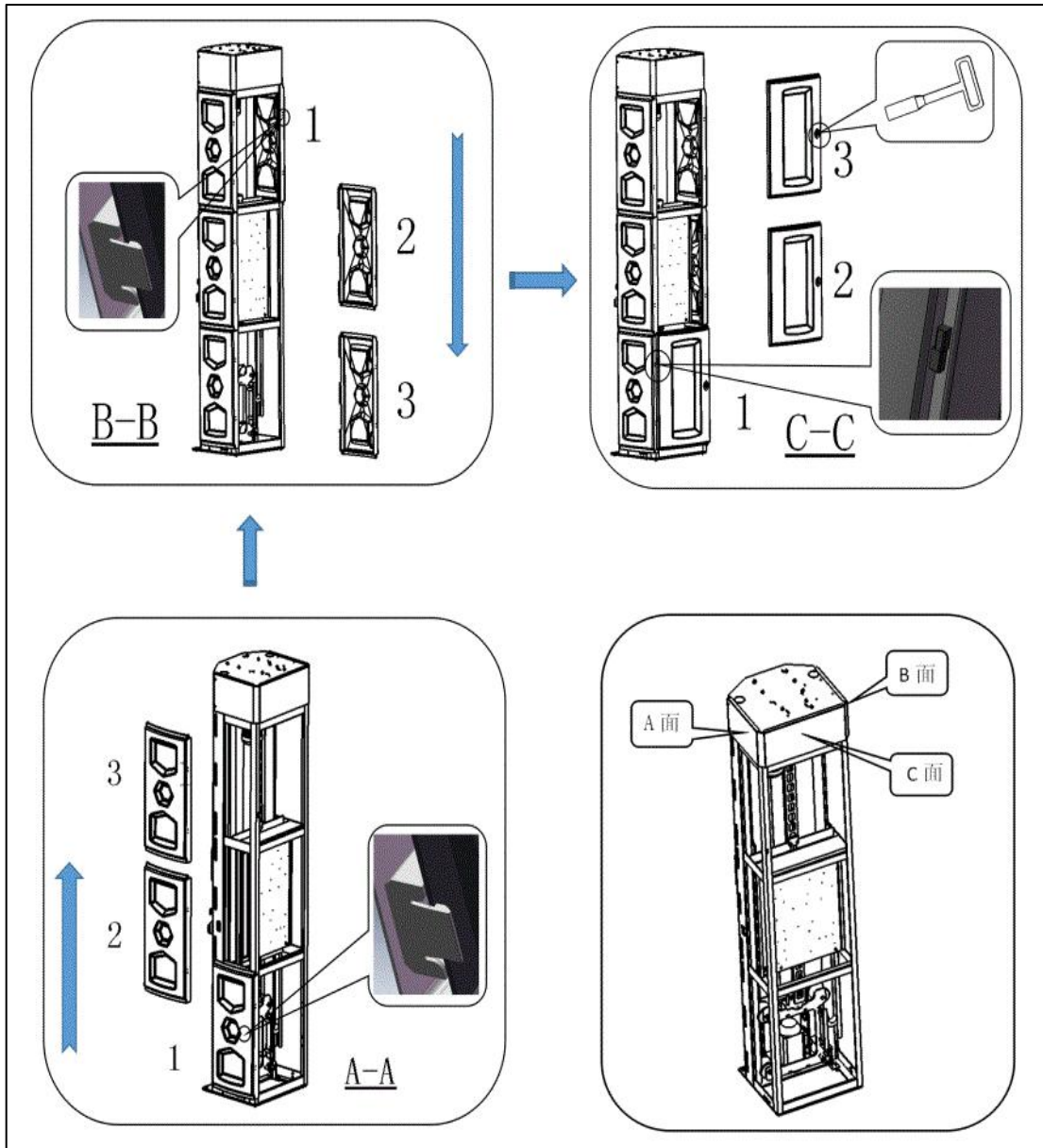

Figure4.5.4.1

5 Operating instructions

5.1 Safety instructions



Notice

Strictly follow the operating safety procedures (see section 2) and the instructions given in this chapter.

5.2 The task of the operator

1. Turn on the machine. See section 5.3.
2. Install and replace film. See Section 5.4.
3. Put a pallet on the turntable. See section 5.5.
4. Fix the end of the wrapping film to the pallets. See section 5.6.
5. Select a mode (See section 5.10) or to continue the current packaging mode.
6. Please refer to section 5.7 for starting the wrapping procedure.
7. The machine will complete a completed packaging cycle. When this cycle is completed, the pallet will stop at the original position.
8. Remove the pallet from the turntable.
9. Turn off the machine (see Section 5.8).



Note: the above tasks of the operator are performed in accordance with the standard working process.

5.3 Start the machine

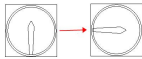
1. Turn the main switch clockwise (A) 
At this point, the power indicator (C) will be on.

2. In case of emergency, press the emergency stop button(B).

5.4 Install and replace wrapping film

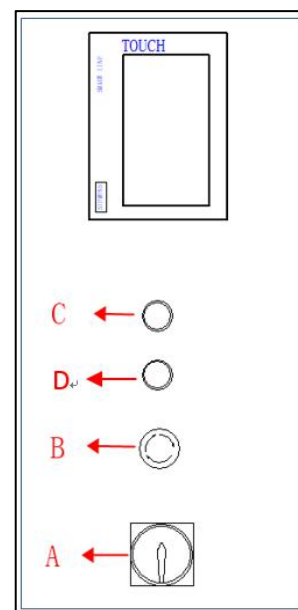

Notice

Please use the same type of film roll as given in section 3.5.1.

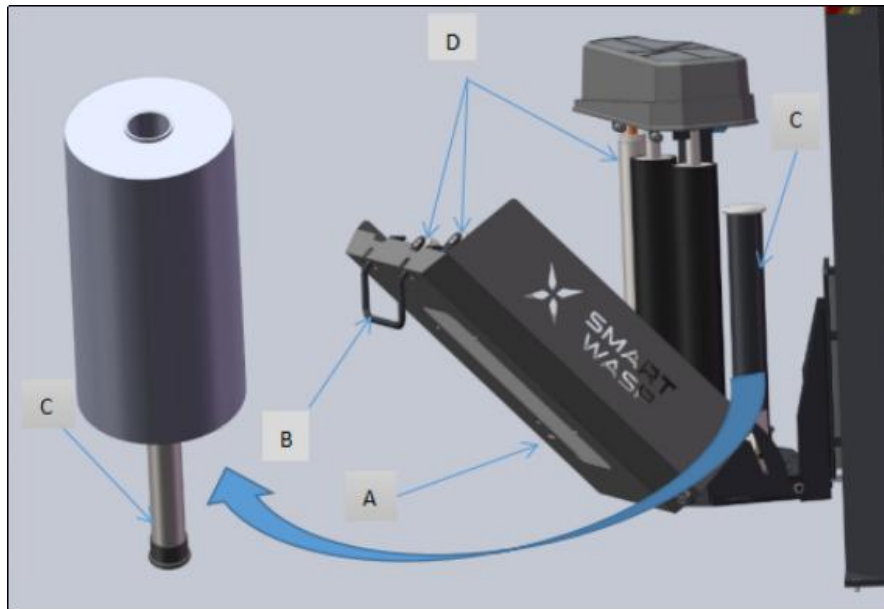

1. Lift the handle (B) up to open the film carriage door (A).
2. Place the stretch film on the film roll holder (C).
3. Pull out the stretch film through the guide roller (D) as indicated on the diagram at the top of the film roll.

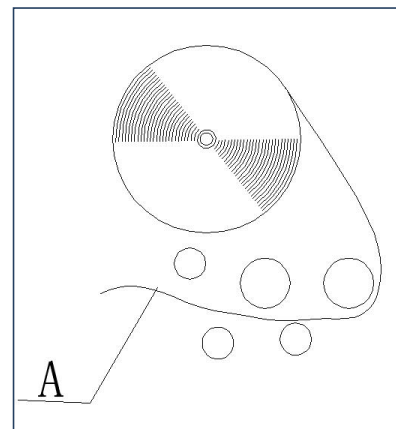

Notice



Most types of stretch film have an adhesive surface (A), so called adhesion side. Since the inner side of the pallet must be covered with sticky material, make sure that this side is glued to the surface. If not, place the stretch film as shown on the right picture.

4. Close the film carriage door.
5. Attach the end of the pulled film to the pallet and the machine is now ready to wrap.

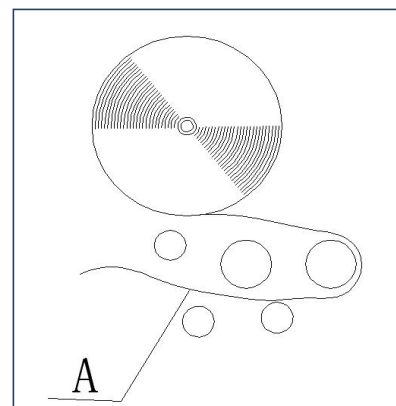

5.5 Place pallet instructions

The operation of the standard wrapping machine can be done by an operator, and the basic flow is shown in the following figure.

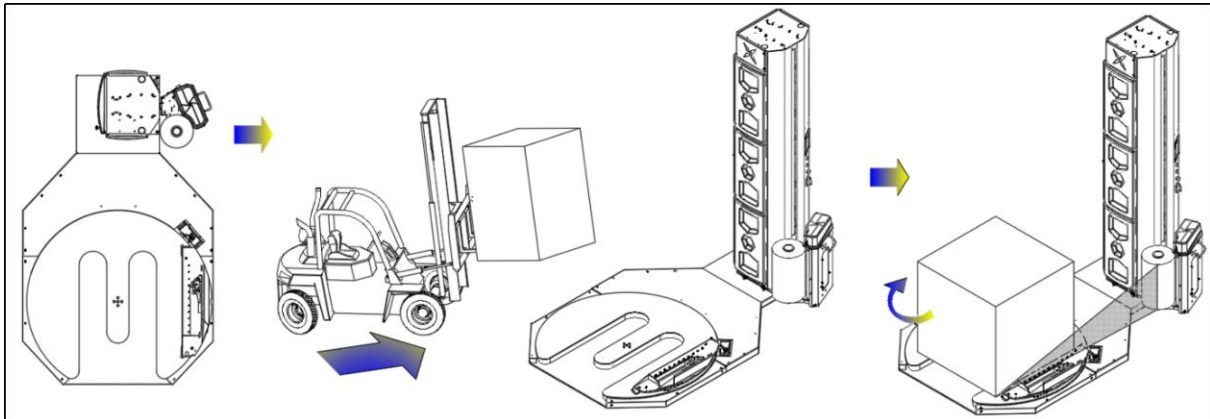

1. Please first make sure there are no people or obstacles within 1 meter of the machine.
2. The pallets are transported by forklift to machine and placed it as far as possible in the center of the turntable.

Note

X100 has a printed film-breaking area. After loading, ensure that one corner of the goods is in the film-breaking area, as shown in the figure below.

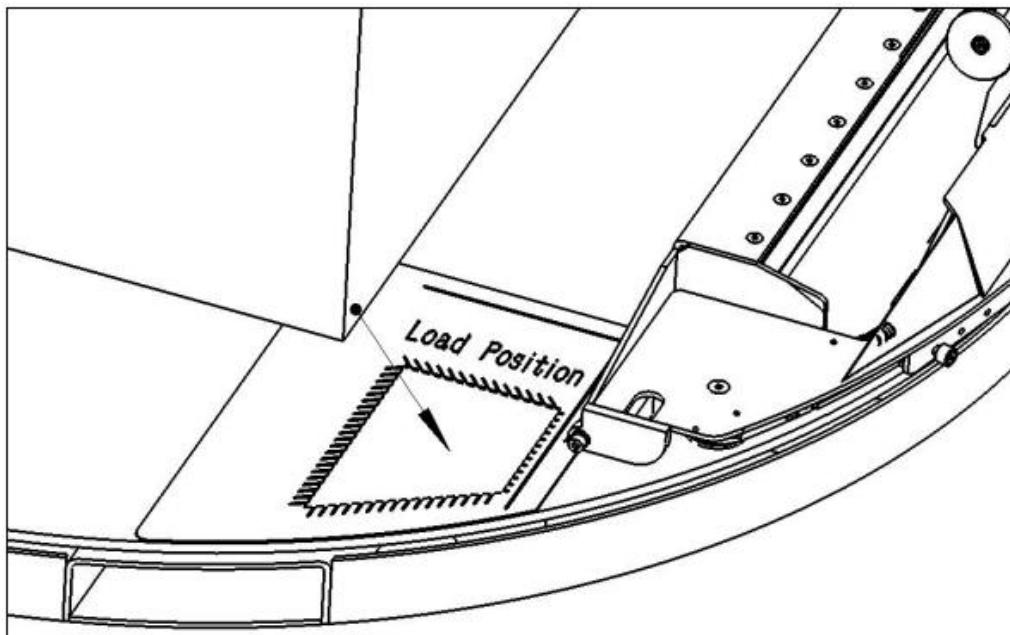

5.6 First put film operation

After the pallet is placed, the wrapping film needs to be manually placed on the machine film roll holder. The operation flow is shown in the figure below.

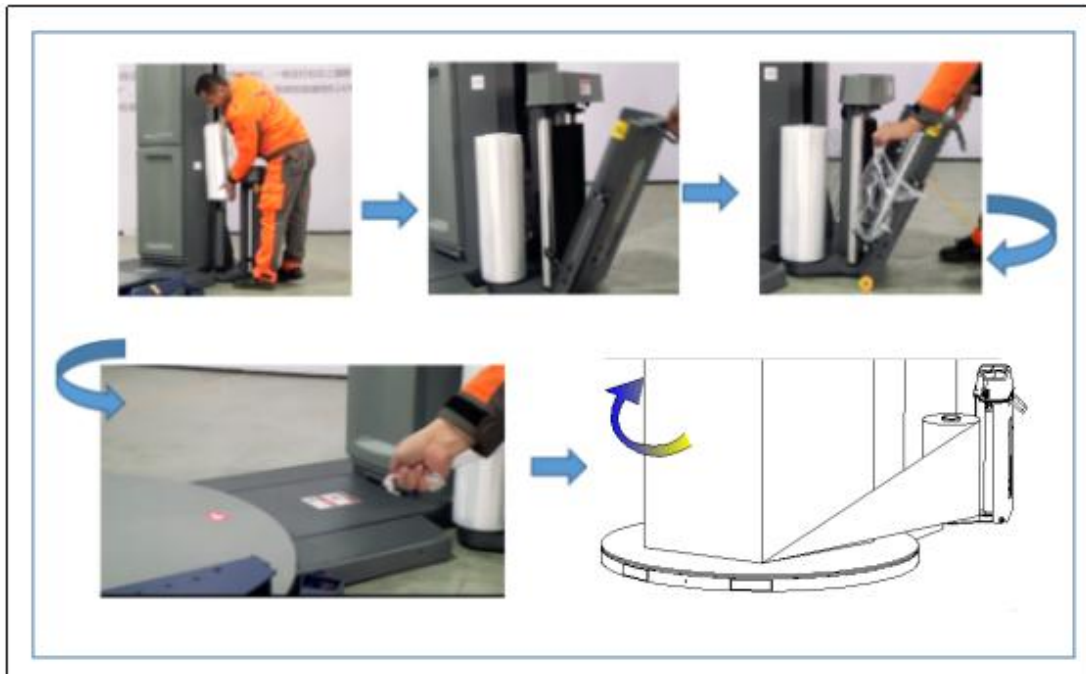

1. After the film roll is placed, manually stretch the film to a sufficient length.
2. Make the film unfold.
3. Pull out the film and attach it to the pallet, firmly stick or tie it to the bottom of the pallet so that it does not fall when it is rotated.

5.7 Turn on the equipment

1. Check for an error message. See section 7.2.
2. Multiple buttons to start the machine:
 - The start button on the column
 - The start button on the screen screen

Press the start button and the voice speaker will make a start sound. After 2 seconds, the turntable began to rotate, and as the film holder rose, the pallet was wrapped. At the end of the wrapping cycle, the turntable stops at the original position.

Notice

In the wrapping process, the machine can be paused.

5.8 Turn off the equipment

If you don't use the machine for a long time, please shut down the machine.

Turn the right switch counterclockwise.

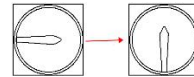

5.9 Touch screen homepage

1. Click to enter the system to enter the touch screen operation



2. Touch screen password:

*administrator:









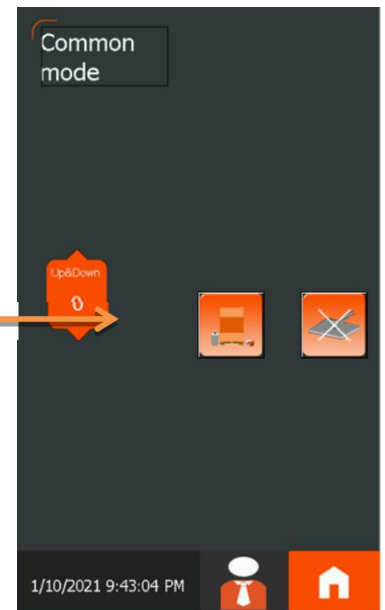
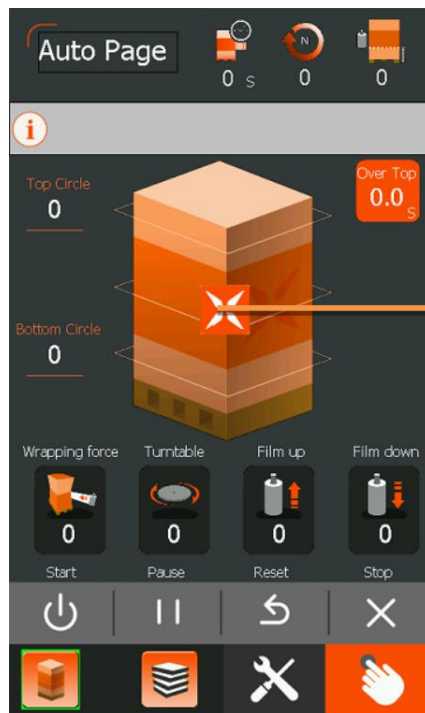

131419





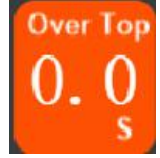



*operator:



123456



NO.	Name	Icon	Descriptions in single layer
A	Wrapping mode setting		The wrapping number of stretch film required at the top (reference value is 2)
			The wrapping number of stretch film required at the bottom (reference value is 2)
			The number of times the pallets are wrapped up and down (reference value is 1)
			This value indicates the time to continue rising after detecting the height of the cargo (reference value of 2.5).
B	Speed setting		Wrapping speed: The speed at which the film is released from the film. As the turntable speed increases, the film exit speed also increases to control the film tension (set range 0-100).
			Turntable speed: the rotation speed of turntable(setting range 0-100)
			Up speed: the rise speed of film carriage

			Down speed: the descending speed of film carriage
C	Basic operation button		Start: Control machine runs automatically
			Pause: pause the current action of the machine. Press any button to end the pause state
			Reset: 1. Move the device to the origin position, and the device can be started only at the origin position 2. Alarm recovery
			Stop button: stop automatic operation state
D	Mode selection		There are 12 cargo modes, and different cargo parameters are written into different modes. Select the corresponding cargo mode before starting to write the parameters into the automatic screen.
E	Manual		Independent control of different positions of the equipment.
F	Setting		The administrator's operation of parameters on controlling device stability.

5.10 Pause packaging (normal stop)

During the packaging cycle, the machine can be temporarily stopped.

1. Press the pause button on the touch screen and the machine will gradually slow down and

stop.

2. Restore the package state by pressing any one of the start buttons.



Notice

After pressing the Pause button and starting again, the machine will continue to run from where it left off until the packaging process is completed.

5.11 Stop in automatic mode (emergency stop)

In emergency circumstances:

Press the emergency stop button (B).

The machine will stop immediately and the packaging program will stop.

Notice

After pressing the emergency stop, the packing cycle could not be resumed.

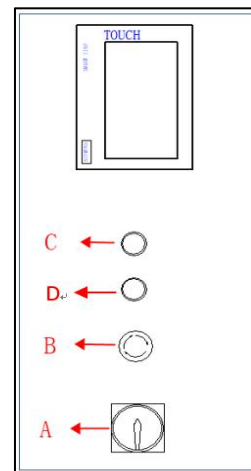

5.12 Reset to the origin position



When the turntable is not at the origin position:

Press the reset button ,

the machine will automatically reset to the home position.

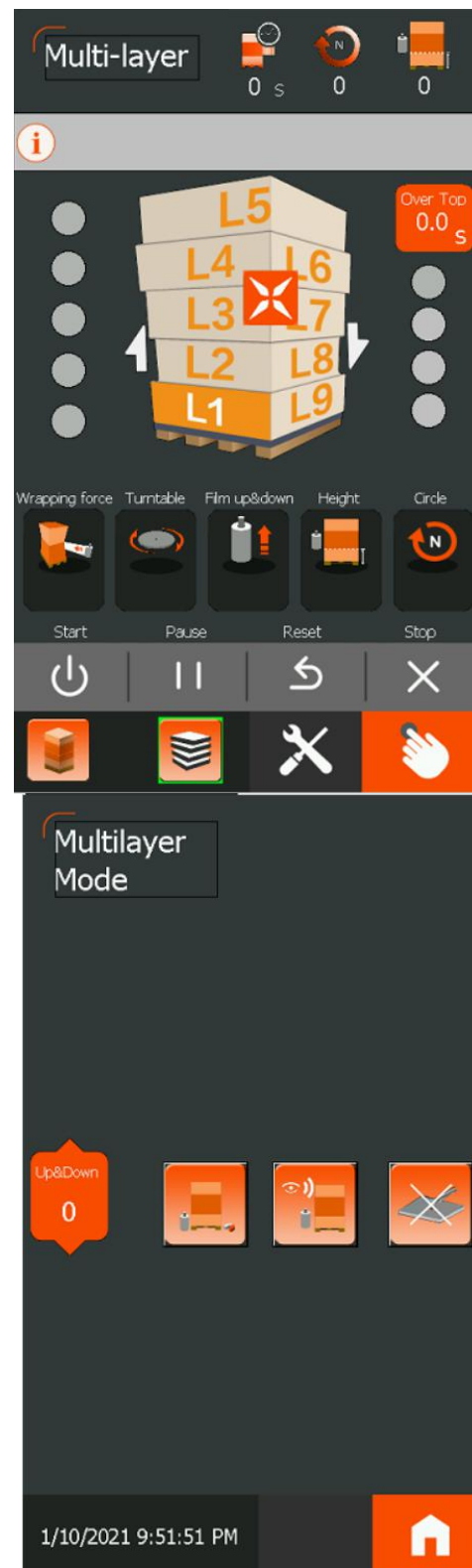
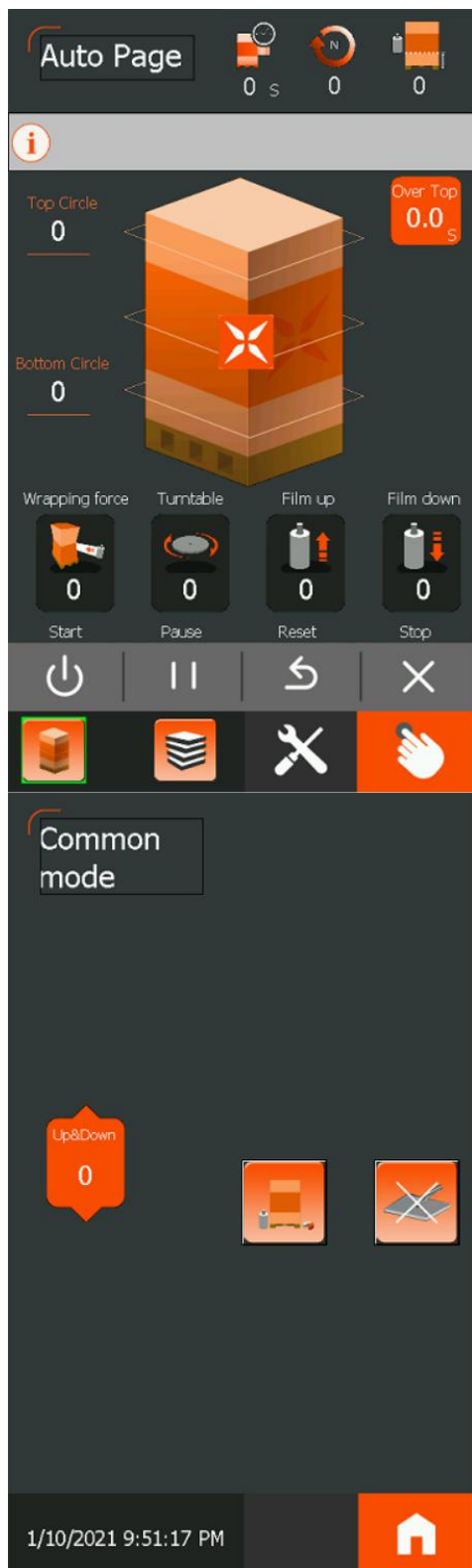
5.13 Select packaging mode



1. Press  and  can switch between modes
2. After switching to the selected mode, press the home page to select the

corresponding mode and write the corresponding parameters into the automatic screen and return to the home page.

3. Press  will appear the single and multi-layer mode settings screen

4. Press  can shield the top of the film





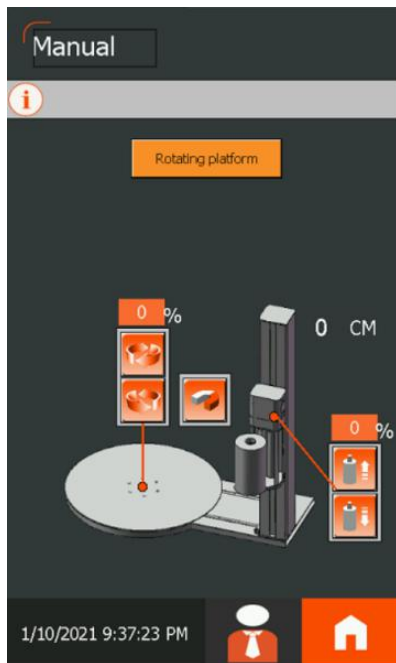

5. Press  shielded pressurization

6. Press  can select photoelectric induction height measurement and multi-layer height setting height measurement

5.14 Manual operation

select manual operation mode from the screen:







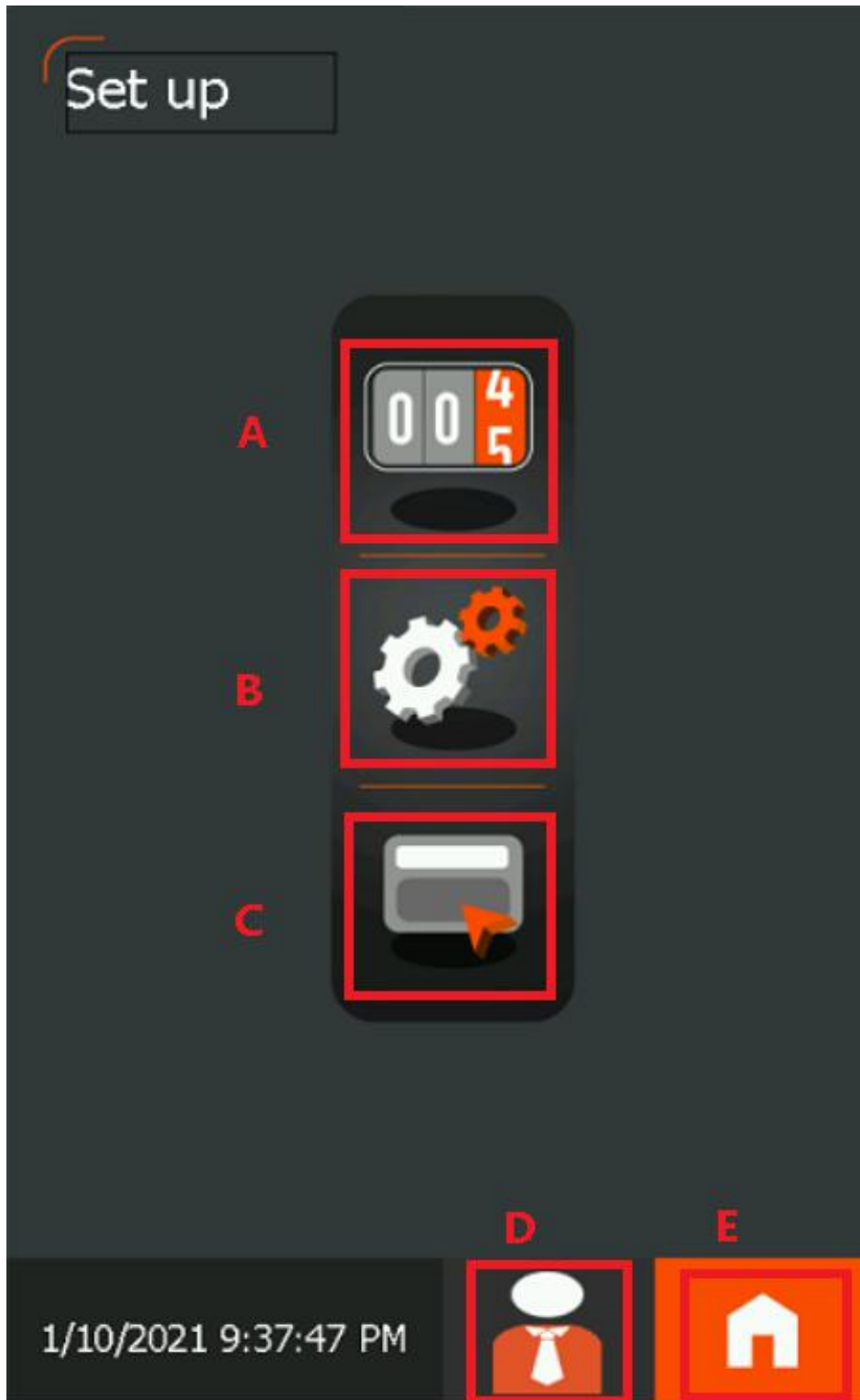

1. Press  come to the manual page
2. Press  the turntable will rotate, press again the turntable will stop rotate
3. Press  the film carriage will rise, press again the carriage will stop
4. Press  the film carriage will fall, press again the carriage will stop
5. Press  the stopper will work
6. Press  the top pressure rod will rise, press again will stop
7. Press  the top pressure rod will fall, press again will stop

Note

The speed of manual operation is set above the corresponding button.

5.15 Setting overview



NO.	Name	Icon	Description
A	Count statistics		Wrapping number statistics
B	System parameter		System parameter setting, password is required to enter, operator setting is prohibited
C	Device Information		Language switching, alarm information, IO monitoring, version information
D	Login status		Display current user login status
E	Homepage		Return to the automatic page

6 Maintenance and repair instructions

6.1 Safety instructions



Notice

Strictly follow the applicable safety instructions during maintenance (see section 2.2.10) and the instructions given in this chapter.

6.2 Maintenance preparation

·Please follow the general safety instructions.

Before starting any maintenance work (or cleaning):

- Turn off the machine
- Remove the power plug

- Wait at least two minutes

6.3 End maintenance check

1. After the maintenance work is completed, please reactivate or enable (temporarily) disable the features of the security facility immediately.
2. After cleaning the machine, please check whether the safety facilities function can be used normally before production.

6.4 Maintenance schedule

Maintenance Tasks	chapters and sections	Maintenance interval			
		Daily check	Monthly Check	Annual inspection	Check every 3 months
Check the function of the safety facility	6.5	√			
Cleaning machine	6.6		√		
Cleaning the drum on the membrane seat	6.7		√		
Lubricate the film carriage drive chain	6.8				√
Check whether the cloth belt on the upright post is worn	6.9				√
Lubricate the belt bearing seat	6.10				√
Lubricate the turntable drive chain	6.11				√
Check the tension of the drive chain in the column	6.12				√
Check the wheel of the turntable	6.13			√	

6.5 Check the function of safety facilities

Notice

Please be extremely careful with the machines that need to be run during the inspection of safety facilities.

1. Check that all safety labels and instructions are legible.
2. Check whether the wire is damaged.
3. Please check the following facilities.
 - Emergency stop button (Please see section 2.5.2);
 - Safety switch for film carriage door (Please see section 2.5.3);
 - Safety film carriage button anti-drop device

6.6 Cleaning machine

1. Check that the device is safe, see section 6.2.
2. Clean the machine with a dry cloth or a mild detergent.



Notice

Do not use solvent, gasoline and other items cleaning machine

6.7 Clean the roller on the film carriage



Notice

Some types of film leave a layer of adhesive on the surface of the drum, which causes the film to slide on the drum.

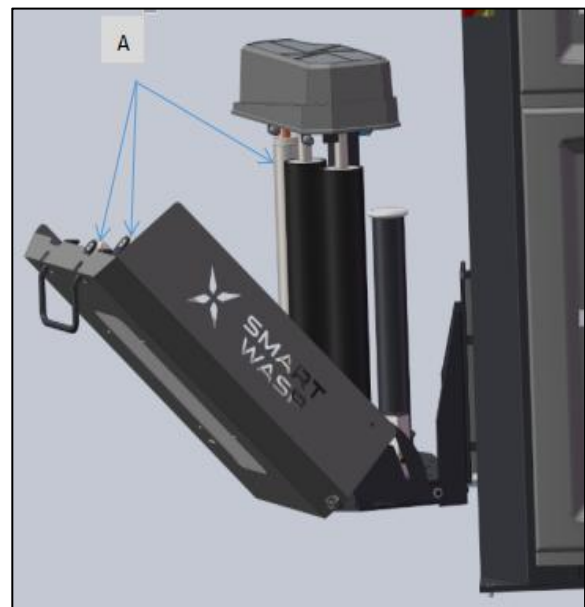

1. To check that the device is safe, see section 6.2.
2. Rubbing the surface of the drum (A) with alcohol will restore adhesion between the drum and the film.



6.8 Lubricate film carriage bottom drive chain



Notice

Before leaving the factory,  lubricating oil has been added to the drive chain of the film seat. Lubricating oil  is still needed for long-term use.

1. Please refer to section 6.2 to check that the device is safe and correct.
2. Raise the film carriage to a suitable height and open the bottom safety plate (B).
3. Lubricate the drive chain with chain grease (A).
4. Close the bottom safety board (B).

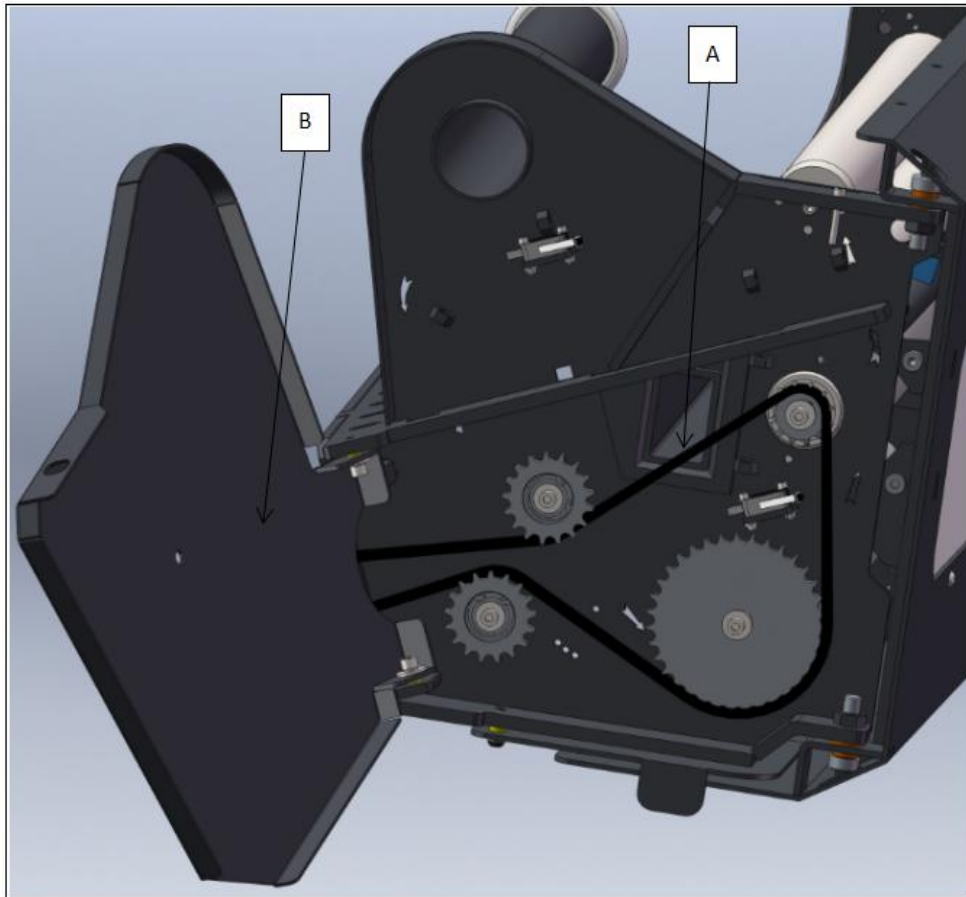

6.9 Lubricate film carriage bottom drive chain



Notice

If the belt on the column is severely worn or cracked, please replace it immediately.



1. Check the safety of the system, please refer to Section 6.2.
2. Open the top coaming and open the door panel. Refer to the door panel (A) installation in Transportation and Installation Instructions for the disassembly process.
3. Check the wear of the belt (B) and whether there are cracks.



6.10 Lubricate the belt bearing seat

Notice

If the belt on the column is severely worn or cracked, please replace it immediately.

Before leaving the factory,  lubricating oil has been added to the bearing block of the column. Lubricating oil  is still needed for long-term use.

1. Check that the system is safe and correct, please refer to Section 6.2.
2. Open the top coaming and open the door plate. Please refer to the door (A) installation of column in the transportation and installation instructions for the removal process.
3. Add lubricating oil to the filling port of the bearing seat (A) of the lifting power frame.

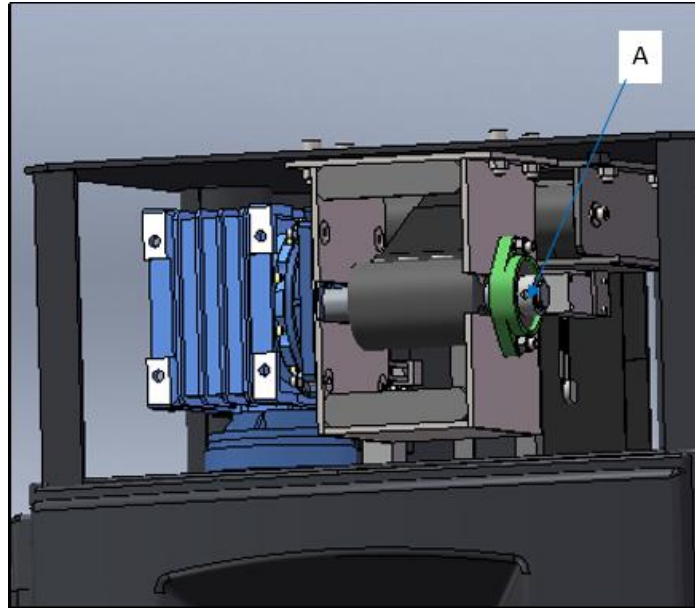

6.11 Lubricate the turntable drive chain



Before leaving the factory, lubricating oil has been added to the drive chain of the film seat. Lubricating oil  is still needed for long-term use.

1. Check that the system is safe and correct, please refer to Section 6.2.
2. Loosen the fastener (A).
3. Remove the chain cover (B).
4. Remove the chain cover (B).
5. Install the chain cover.

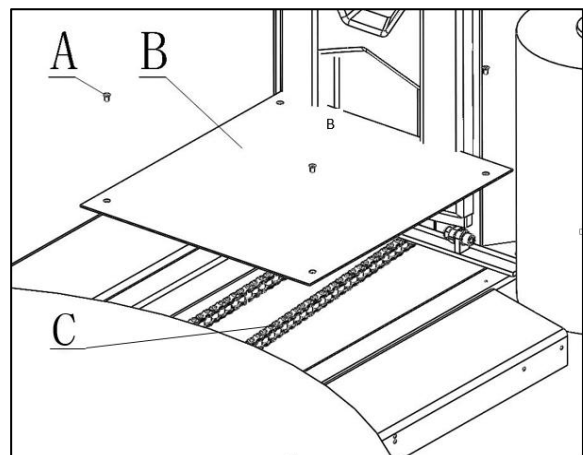

If the chain is loose, tension the chain as follows:

1. Open the door panel.
2. Loosen the four fasteners (B) of the welding parts of the motor mounting plate.
3. Use the chain tension bolt (B) to adjust the chain tension.

4. Tighten the four fasteners (A).
5. Check the tension of the transmission chain again.
6. After the adjustment is completed, proceed in the reverse order to reinstall the removed parts.

6.12 Check the chain tension of the turntable drive chain

Check that the system is safe, please refer to section 6.2

Loosen the 4 fasteners (A) on the turntable (B).

Remove the turntable (B).

Check the condition of the next round (A).

Replace the wheel assembly. After the adjustment is completed, proceed in the reverse order to reinstall the removed parts.

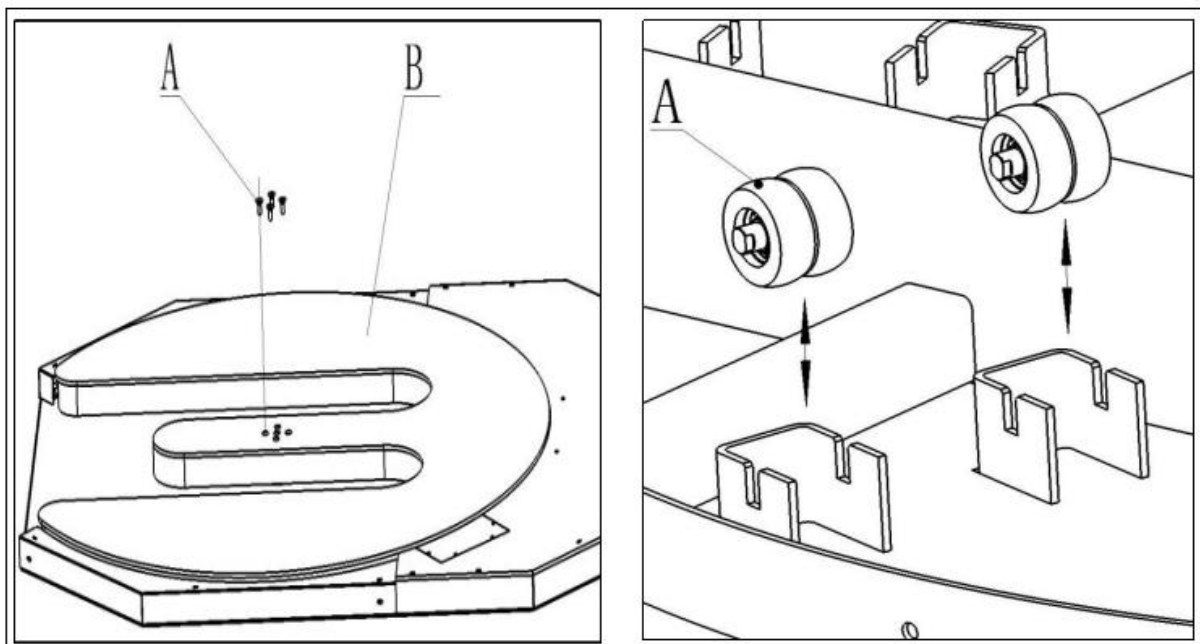

7 Trouble shooting instructions

7.1 Safety precautions



Notice

Strictly observe safety regulations

Please refer to section 2.2.11 for repair and troubleshooting.

7.2 Troubleshoot

7.2.1 Touch screen (HMI) alarm condition description

The possible causes of the alarm information prompted by the touch screen and the solutions to be taken are as follows.

NO.	Problem description	Possible reasons	Solution
1	Lack of material alarm	1) The stretch film is out. 2) Stretch film is broken when the machine is in operation	1) Change film 2) Pull the film out and put it on the goods.
2	Abnormal alarm of anti-pressure switch of film carriage	1) anti-pressure switch press some objects 2) The wire of anti-pressure switch falls off. 3) Anti-pressure switch is broken.	1) Check that there's something under the film seat. 2) Check whether the anti-pressure switch wire is falling off or not. 3) Check whether the anti-pressure switch element is in good condition. 4) Press the anti-pressure switch at the same time to observe whether the

			PLCI1. O is on or not, and if not, replace the anti-pressure switch.
3	Belt anti-loose switch abnormal alarm	<p>1) The travel switch is not in the center of the belt.</p> <p>2) The mounting between the membrane seat and the column is not removed.</p> <p>3) The travel switch is broken.</p>	<p>1) Adjust the center of the belt and travel switch</p> <p>2) Remove the mounting parts between the film seat and the column</p> <p>3) Replace travel switch</p>
4	Emergency stop alarm	<p>1) Emergency stop button is pressed</p> <p>2) Emergency stop button is broken.</p>	<p>1) Release emergency stop</p> <p>2) Replace new emergency stop button.</p>
5	Prohibit operation after lifting up to the upper limit	The film seat reaches the upper limit and cannot rise again.	Control the film seat to fall down in manual mode
6	Manually lowering the film carriage, prohibiting rising it.	When the film seat is lowered in manual mode, click on the rise operation.	Do not click rise in manual mode when the film seat is manually go down.
7	Do not click go down in manual mode when the film seat is manually rise.	When the film carriage is going down in manual mode, the operator click on the rise button.	Do not click go down in manual mode when the film seat is manually rise.
8	After the film seat reaches the lower limit, it is forbidden to continue to descend.	The film seat reaches the lower limit when it is manual mode.	The film seat reaches the lower limit when it is manual mode, and cannot continue to descend.
9	Prohibit click start button in touch screen in manual action.	Automatic state start cannot be activated in manual state	Reset first, and then start.

10	Manual mode is prohibited when the machine is running in automatic mode.	Manual mode is prohibited when the machine is running automatically	Wait until the automatic run is complete and then manually operate it.
11	The safety door of the film seat is open.	1) The safety door of the film seat is open. 2) The circuit of proximity switch is damaged.	1) Check that the safety door is closed. 2) Check that the wire is in good condition.
12	Lifting motor alarm	Inverter alarm	Check the inverter code to find the reason
13	Film seat motor alarm	Inverter alarm	Check the inverter code to find the reason
14	Turntable motor alarm	Inverter alarm	Check the inverter code to find the reason
15	Touch screen show “##”.	1) Connection cable is damaged 2) Network cable plug is not plugged in	1) Replace the network cable 2) Check the plug

7.2.2 Description of inverter alarm

The alarm information displayed on the operation panel of the inverter, possible causes, and solutions to be taken are as follows.

NO.	Fault	Cause	Remedy
1	F1 Overcurrent	<ul style="list-style-type: none"> • Motor power (P0307) does not correspond to the inverter power (r0206). • Motor lead short circuit • Earth faults r0949 = 0: Hardware reported r0949 = 1: Software reported	<ul style="list-style-type: none"> • Check the following: • Motor power (P0307) must correspond to inverter power (r0206). • Cable length limits must not be exceeded. • Motor cable and motor must have no short-circuits or earth

		r0949 = 22: Hardware reported	<p>faults.</p> <ul style="list-style-type: none"> • Motor parameters must match the motor in use. • Value of stator resistance (P0350) must be correct. • Motor must not be obstructed or overloaded. • Increase ramp-up time (P1120) • Reduce starting boost level (P1312)
2	F2 Overvoltage	<ul style="list-style-type: none"> • Main supply voltage too high • Motor is in regenerative mode <p>r0949 = 0: Hardware reported r0949 = 1 or 2: Software reported</p>	<p>Check the following:</p> <ul style="list-style-type: none"> • Supply voltage (P0210) must lie within limits indicated on rating plate. • Ramp-down time (P1121) must match inertia of load. • Required braking power must lie within specified limits. • Vdc controller must be enabled (P1240) and parameterized properly. <p>Note: Regenerative mode can be caused by fast ramp downs or if the motor is driven by an active load. Higher inertia requires longer ramp times; otherwise, apply braking resistor.</p>
3	F3 Undervoltage	<ul style="list-style-type: none"> • Main supply failed. • Shock load outside specified limits. <p>r0949 = 0: Hardware reported r0949 = 1 or 2: Software reported</p>	Check supply voltage.
4	F4 Inverter overtemperature	<ul style="list-style-type: none"> • Inverter overloaded • Ventilation inadequate • Pulse frequency too high • Surrounding temperature too high • Fan inoperative 	<p>Check the following:</p> <ul style="list-style-type: none"> • Load or load cycle too high? • Motor power (P0307) must match inverter power (r0206) • Pulse frequency must be set to

			<p>default value</p> <ul style="list-style-type: none"> • Surrounding temperature too high? • Fan must turn when inverter is running
5	F4 Inverter overheated	<ul style="list-style-type: none"> • Inverter overload • Insufficient ventilation • Pulse frequency is too high • The ambient temperature is too high • Fan is not working 	<p>Check the following:</p> <ul style="list-style-type: none"> • Is the load or duty cycle too high? • The motor power (P0307) must match the inverter power (R0206). • Pulse frequency must be set to the default value • The ambient temperature is too high? • The fan must rotate when the inverter is running
6	F5 Inverter I2t	<ul style="list-style-type: none"> • Inverter overloaded. • Load cycle too demanding. • Motor power (P0307) exceeds inverter power capability (r0206). 	<p>Check the following:</p> <ul style="list-style-type: none"> • Load cycle must lie within specified limits. • Motor power (P0307) must match inverter power (r0206) <p>Note: F5 cannot be cleared until the inverter overload utilization (r0036) is lower than the inverter I2t warning (P0294).</p>
7	F11 Motor overtemperature	<ul style="list-style-type: none"> • Motor overloaded 	<ul style="list-style-type: none"> • Check the following: • Load or load step too high? • Motor nominal overtemperatures (P0626 - P0628) must be correct. • Motor temperature warning level (P0604) must match.
8	Film carriage back films	<ol style="list-style-type: none"> 1. Film seat power roller reverse 2. The film carriage is not tightened during operation 	<ol style="list-style-type: none"> 1. Check the wiring, and U2/V2 can be exchanged if necessary 2. Tighten the film to prevent film roll
9	No action when the machine starts	<ol style="list-style-type: none"> 1. The power is not plugged in 2. The emergency stop button is pressed 3. Inverter alarm 	<ol style="list-style-type: none"> 1. Plug in the power plug 2. Rotate the emergency stop button to eliminate emergency

			stop 3. Press the "OK" button of the inverter
10	A501 Current limit	<ul style="list-style-type: none"> • Motor power does not correspond to the inverter power • Motor leads are too long • Earth faults 	See F1.
		<ul style="list-style-type: none"> • Small motors (120 W) under FCC and light load may cause a high current 	Use V/f operation for very small motors
11	A502 Overvoltage limit	Overvoltage limit is reached. This warning can occur during ramp down, if the Vdc controller is disabled (P1240 = 0).	If this warning is displayed permanently, check inverter input voltage.
12	A503 Undervoltage limit	<ul style="list-style-type: none"> • Main supply failed. • Main supply and consequently DC-link voltage (r0026) below specified limit. 	Check main supply voltage.
13	A504 Inverter overtemperature	Warning level of inverter heat sink temperature, warning level of chip junction temperature, or allowed change in temperature on chip junction is exceeded, resulting in pulse frequency reduction and / or output frequency reduction (depending on parameterization in P0290).	<p>Note:</p> <p>r0037[0]: Heat sink temperature r0037[1]: Chip junction temperature (includes heat sink)</p> <p>Check the following:</p> <ul style="list-style-type: none"> • Surrounding temperature must lie within specified limits • Load conditions and load steps must be appropriate • Fan must turn when inverter is running
14	A506 IGBT junction temperature rise warning	Overload warning. Difference between heat sink and IGBT junction temperature exceeds warning limits.	Check that load steps and shock loads lie within specified limits.

15	A511 Motor overtemperature I2t	Motor overload. Load cycles or load steps too high.	Independently of the kind of temperature determination check: <ul style="list-style-type: none"> • P0604 motor temperature warning threshold • P0625 motor surrounding temperature • Check if name plate data is correct. If not, perform quick commissioning. Accurate equivalent circuit data can be found by performing motor identification (P1900 = 2). • Check if motor weight (P0344) is reasonable. Change if necessary. • With P0626, P0627, and P0628 the standard overtemperature can be changed, If the motor is not a SIEMENS standard motor.
16	A922 No load applied to inverter	No Load is applied to the inverter. As a result, some functions may not work as under normal load conditions.	Check that motor is connected to inverter.

7.2.3 Mechanical common faults and elimination

NO.	Problem description	Possible reasons	Solution
1	The turntable does not rotate after starting.	1. Emergency stop button has been pressed. 2. The chain falls off or breaks	1. Rotate the “Emergency Stop Button” on the operation panel to eliminate the “Emergency Stop Alarm” and the red light at the top will be eliminated.

			2. Open the turntable, replace the chain, adjust the chain tension
2	Abnormal noise or difficulty in starting the turntable	<ol style="list-style-type: none"> 1.The machine is placed on uneven ground 2.Bottom roller damaged 3.The chain is short of lubricating oil 4.The goods are overweight 	<ol style="list-style-type: none"> 1.Place the equipment on the flat ground and ensure the floor is clean. 2.Reinstall the bottom roller or replace it. 3.Filling of lubricating oil. Details refer to Maintenance instructions. 4.Check if the bottom roller is loose or damaged, check the weight of the load(The goods should be selected within the approved load range, and the detailed range values refer to the technical parameter list.)
3	The turntable has no reset action or the reset is not accurate.	<ol style="list-style-type: none"> 1.The bottom sensor of the turntable is loose and damaged. 2.Power lines were damaged. 	<ol style="list-style-type: none"> 1. Adjust the distance between sensor and sensor plate or replace sensor. 2. Check circuit and replace faulty circuit
4	Abnormal noise in film carriage	<ol style="list-style-type: none"> 1.Chain lacks lubricant 2.There are something in the chain. 	<ol style="list-style-type: none"> 1.please see section 6 Maintenance and Repair Instructions for details. 2. Clean the matter in the chain
5	The top of the goods can't be packed.	<ol style="list-style-type: none"> 1. Sensor detection position deviation 2. The sensor is damaged. 3. Over top time setting is too short. 	<ol style="list-style-type: none"> 1.Adjust the sensor to detect the distance or position 2. Change sensor 3. Increase the times of over top (Please see section 5 Operating Instructions for details.)
6	Film carriage abnormality	<ol style="list-style-type: none"> 1. Sensor detection position deviation 2. The sensor is damaged. 3. Chains fall off, break, or have something in the chain 	<ol style="list-style-type: none"> 1.Adjust the sensor to detect the distance or position 2.Change sensor 3.Clean up the things or reinstall the chain
7	Film winding too tight / too loose / broken / have	<ol style="list-style-type: none"> 1.The film roll is bonded with debris 2.The film release speed is too 	<ol style="list-style-type: none"> 1. Clean the surface of the film roller with alcohol (do not use sharp tools such as a knife to clean it))

	broken hole	inconsistent with the turntable speed.	2.Adjust the motor speed (Please see 5 Operating Instructions for details)
8	Film carriage roller reverse rotation	1.film carriage power drum reversal 2. The film is not tensioned during operation.	1.Check the circuit and exchange U2/V2 if necessary 2.Tightening film to prevent returning film when operating.
9	No action after the machine starts	1.The power supply is not plugged in. 2.Iverter alarm 3.Emergency stop button has been pressed.	1.Plug in the power plug 2.Press the "OK" button of the inverter. 3.Release emergency stop button

8 Appendix

8.1 Electrical principle drawing

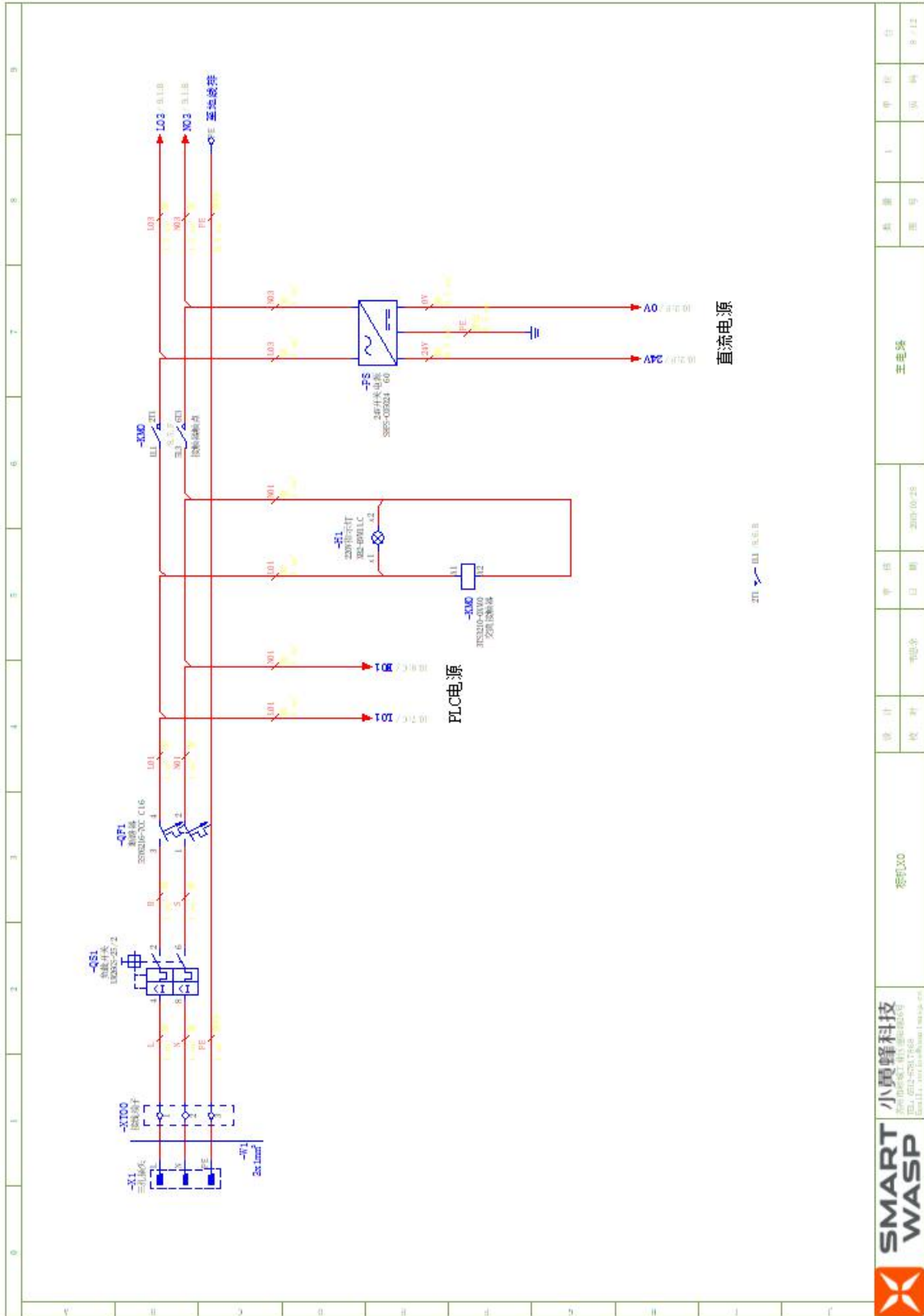

小蜜蜂科技
SMART WASP TECHNOLOGY

睿思100

设计
代 理

日期
日期

主笔
姓名

页 数
页 数

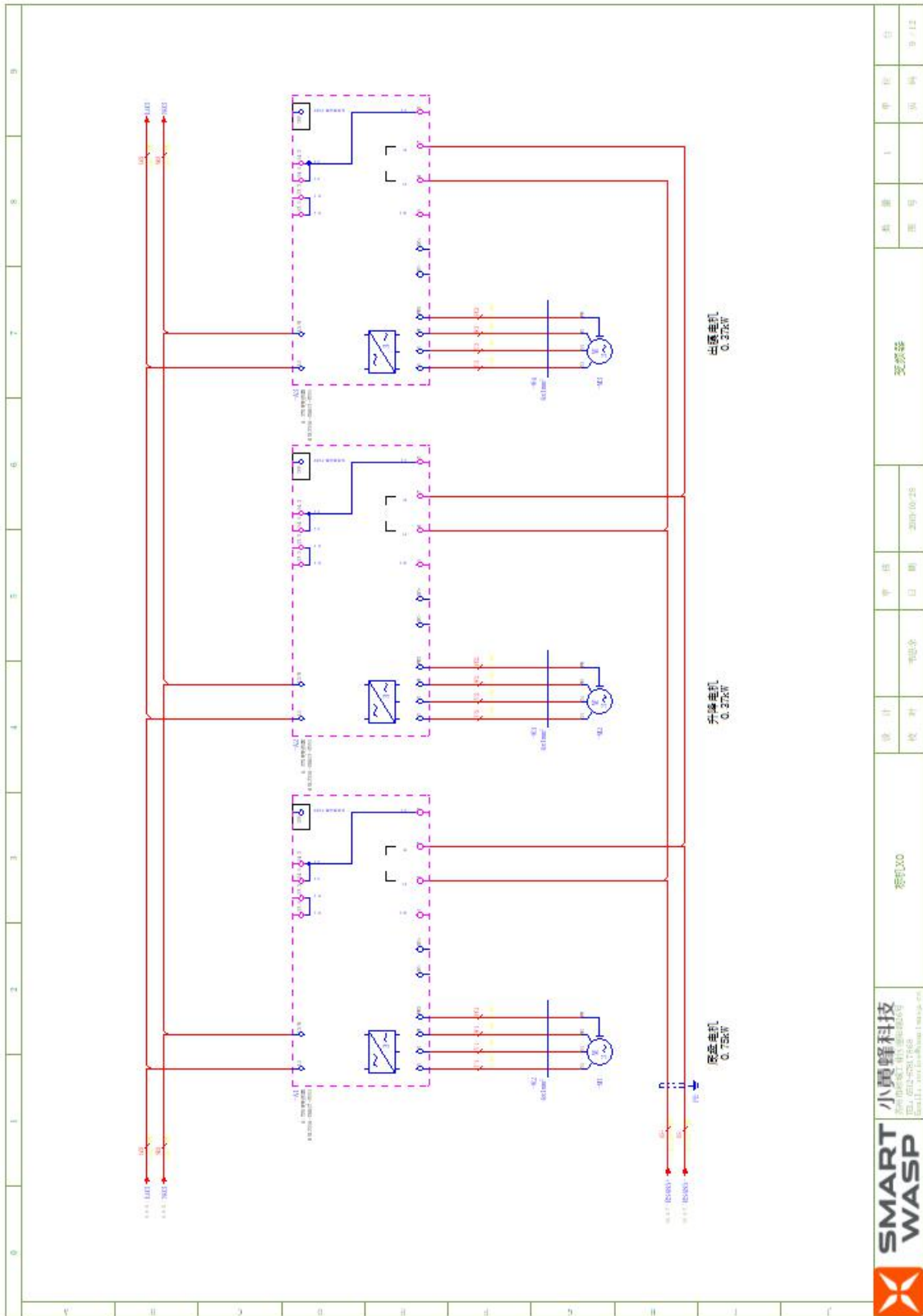

 SMART WASP 小蜜蜂科技 SMART WASP TECHNOLOGY Smart Life, Smart Technology, Smart People	型号	规格	日期	日期	数量	单位	行
	规格	规格	日期	日期	数量	单位	行

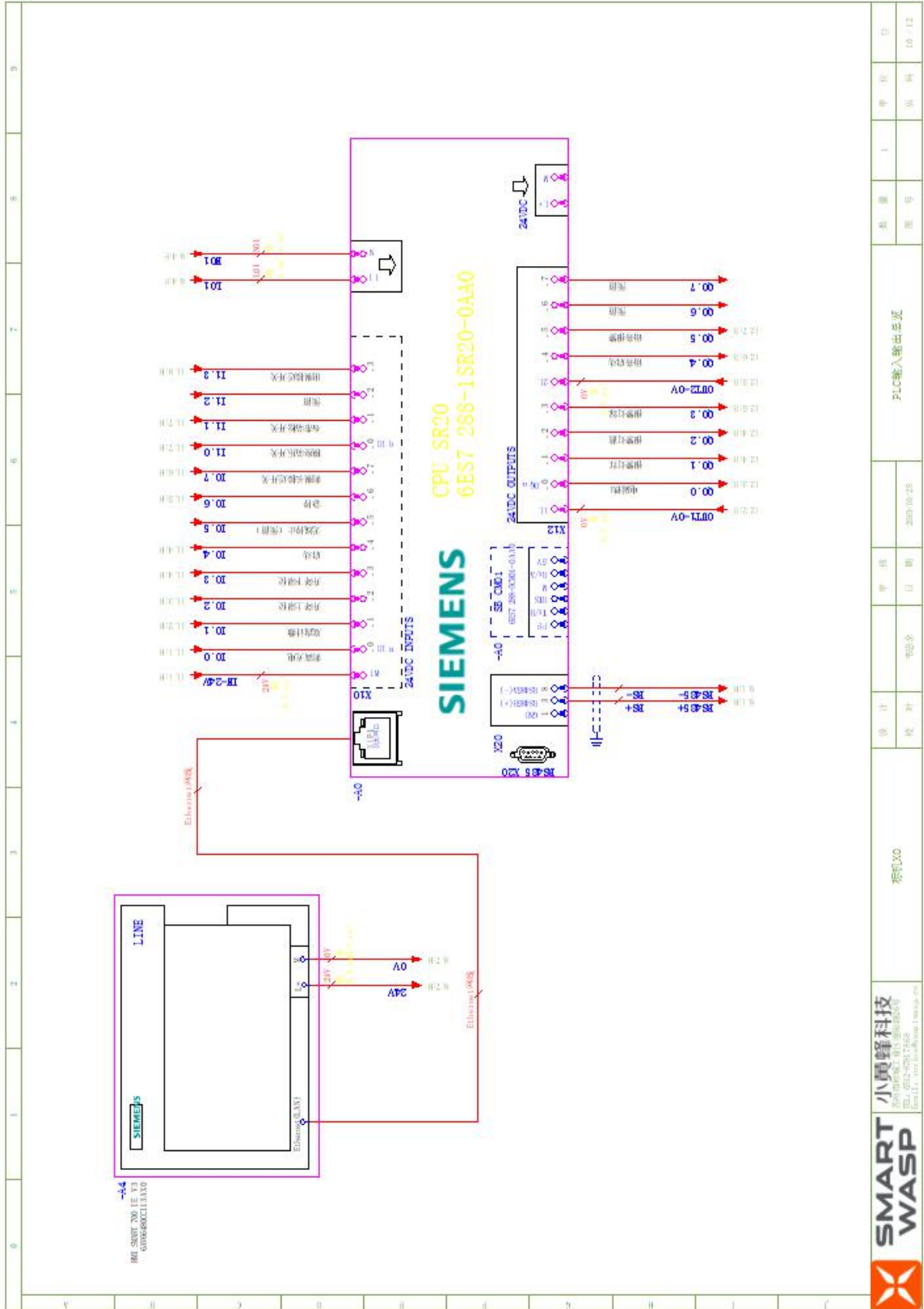

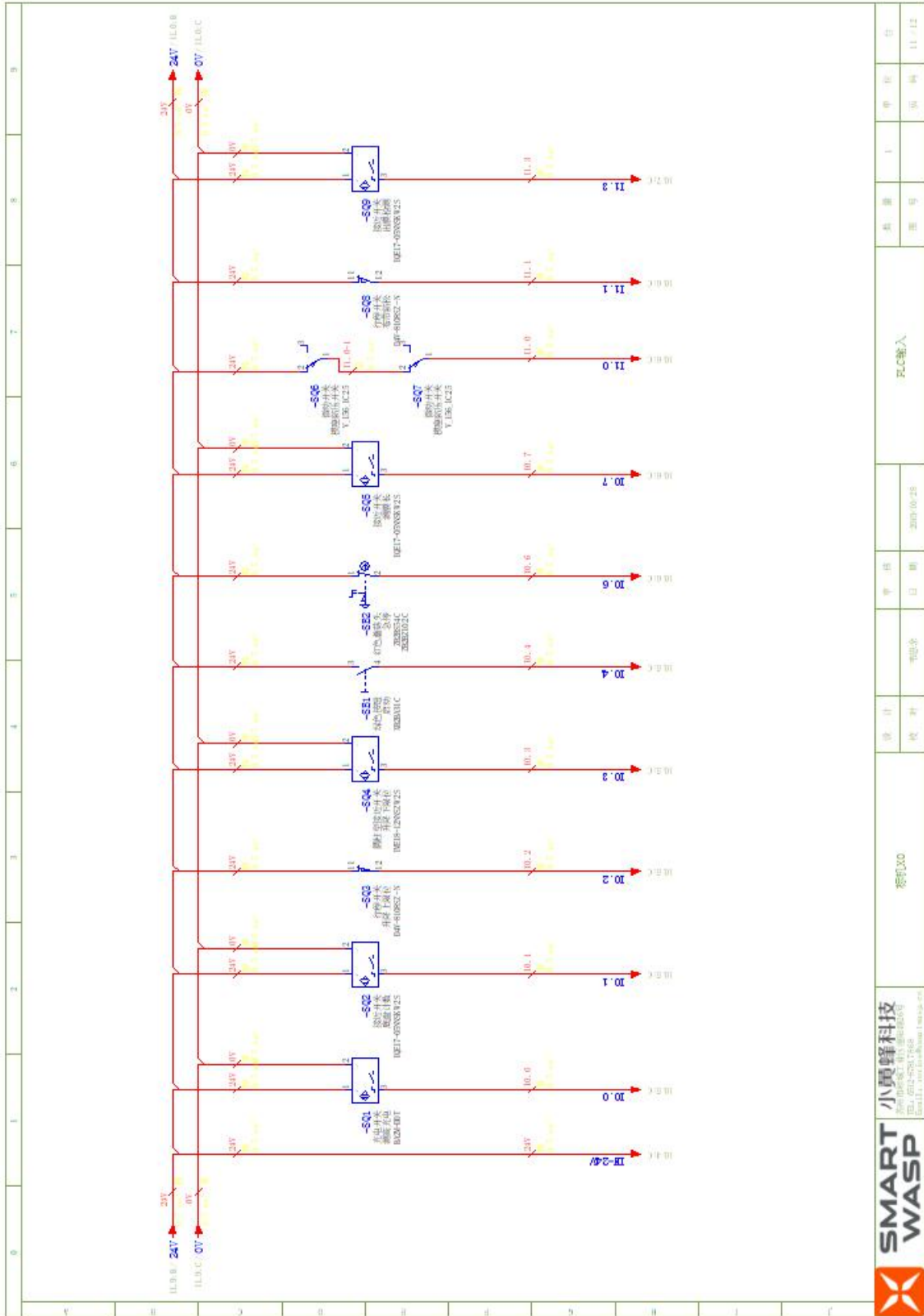

 SMART WASP 小蜜蜂科技 SMART WASP TECHNOLOGY 2001 PARKWAY, SUITE 100, RICHMOND, BC V6X 3E7, CANADA TEL: 604-273-8888 FAX: 604-273-8889 WWW.SMARTWASP.COM	图号: 2009-04-25		设计: 11-12	
	日期: 2009-04-25		审核: 11-12	

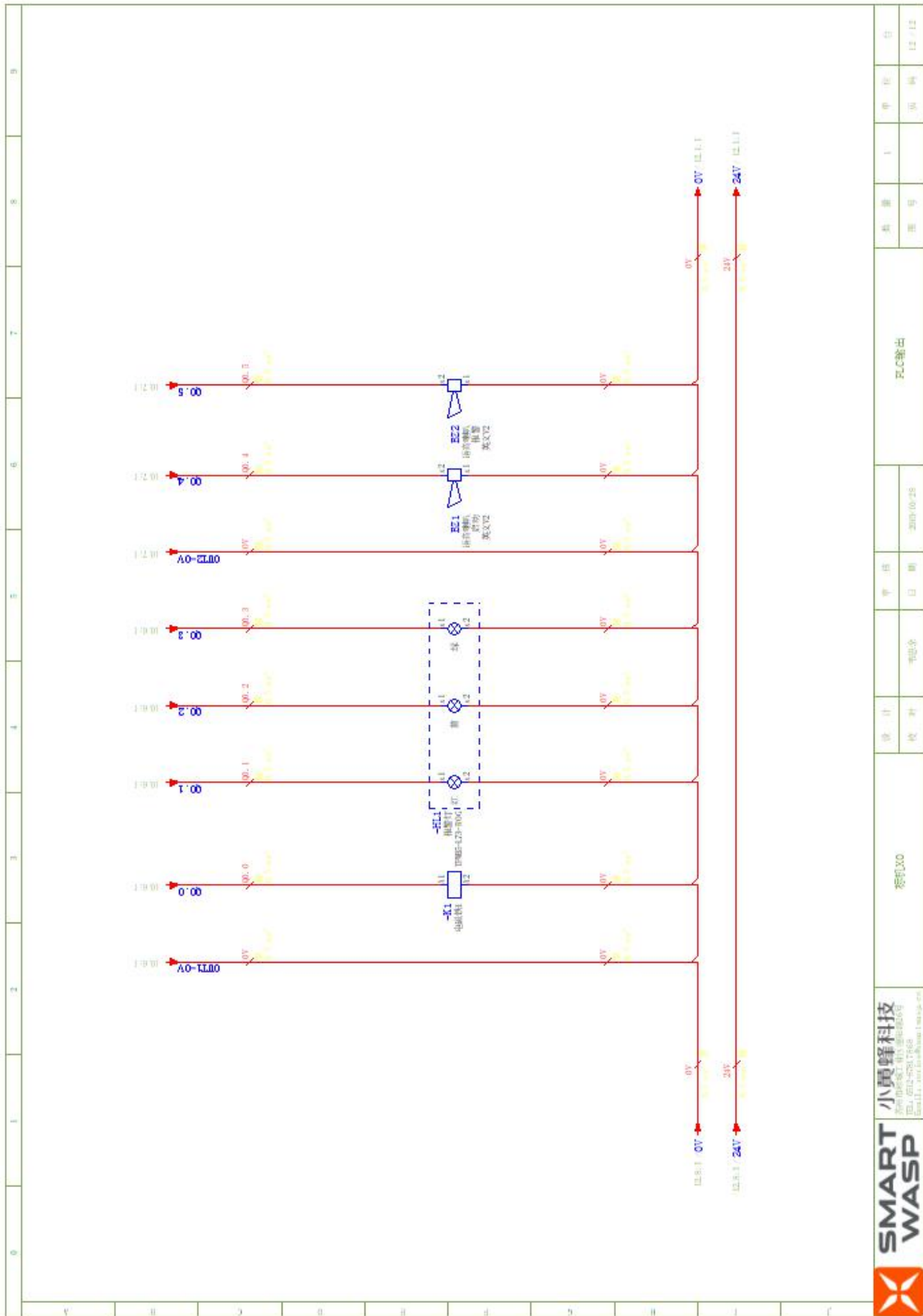

 SMART WASP 小蜜蜂科技 2001 PARKWAY 103, SUITE 103 GAITHERSBURG, MD 20878-4101 TEL: 410-286-1111 FAX: 410-286-1112 WWW.SMARTWASP.COM	图号: 2009-04-25		图名: PLC输出		图号: 12.1.1	图名: 12.1.1
	图号: 2009-04-25	图名: PLC输出	图号: 12.1.1	图名: 12.1.1	图号: 12.1.1	图名: 12.1.1

8.2 Component breakdown diagram and detailed list

8.2.1 Turntable decomposition diagram and schedule

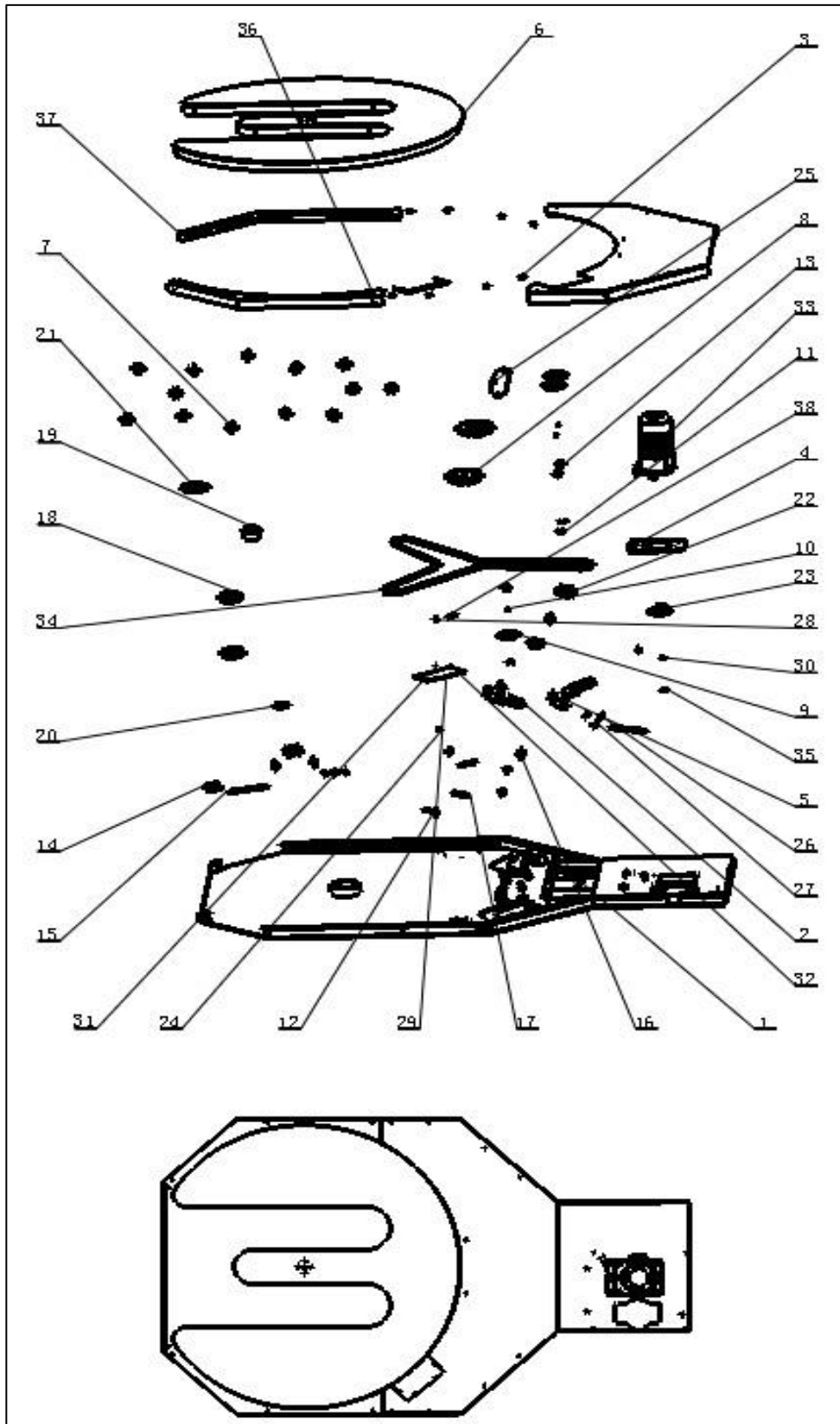

NO.	Workpiece number	Workpiece name	Quantity
1	9XXDI000087	M-type turntable welding basics	1

		(simple version)	
2	9XXDI000048	Right swing arm welding	1
3	9XXDI000081	Cover plate welding	1
4	9XXDA000018	Motor mounting plate welding parts	1
5	9XXDI000047	Left swing arm welding	1
6	9XXDI000026	Turntable welding	1
7	9XXDI000150	Turntable roller assembly	13
8	9XXDI000149	Rubber wheel drive components	2
9	9XXDI000042	Transition sprocket	3
10	d25	Circlip for shaft	3
11	D52	Circlip for hole	3
12	9XXDI000036	Shaft sleeve	4
13	6205	Deep groove ball bearing	3
14	9HXWS000213	Connector	2
15	9XXDI000038	Screw	2
16	9HXWS000215	Fixed piece	4
17	9XXDI000058	Swing arm cover	2
18	JZCJJ000005	Angular contact ball bearing 7017C	2
19	9XXDI000045	Spindle	1
20	9XXDI000059	Spindle gland	1
21	9XXDI000060	Bearing gland	1
22	9HXWS000214	Buffer compression spring	2
23	9XXDI000044	Motor sprocket	1
24	9XXDI000065	Swing arm gland	2
25	9XXDI000032	Center cover	1
26	9XXDI000066	Buffer gasket	4
27	9XXDI000041	Cushion	2
28	9XXDI000075	Induction block	1

29	9XXDI000067	Stopper cover	1
30	9XXDI000068	Motor sprocket gland	1
31	JJGLM000027	Square nut M6	1
32	9XXDI000091	Sensor bracket	1
33	JDJL000013	CV type vertical aluminum housing geared motor	1
34	JQTQT000108	Chain A10	1
35	9XXDA000008	Gland	1
36	9XXDI000084	Side cover 1	1
37	9XXDI000085	Side cover 2	1
38	DKGJJ000008	Cylindrical proximity switch	1

8.2.2 Column exploded view and detail list

1) Column installation exploded view

NO.	Workpiece number	Workpiece name	Quantity
1	9XXLG000273	Side door (new)	3
2	9XXLG000106	Rear door panel	3
3	9XXLG000193	Lifting power unit (lifting motor)	1
4	9XXLG000100	Light guide plate	1
5	9XXLG000101	Light box	1
6	9XXLG000145	Wheel mechanism	1
7	9XXLG000168	Top coaming welding piece	1
8	9XXLG000273	Side door panel (new)	3
9	9XXD0000042	Power Indicator	1
10	9XXD0000041	Start up buttonXB2-BA31C	1
11	9XXD0000043	Load switch LW26GS-25/2	1
12	9XXD0000044	Emergency stop button	1
13	DKGXZ000001	Travel switch	1
14	9XXLG000095	Electrical cover plate	1
15	9XXD0000038	Touch screen (SMART 700IE V3)	1
16	JQTQT000002	Tank drag chain	1
17	DKGJJ000008	Cylindrical proximity switch	1
18	9XXLG000153	Lower limit switch mounting bracket	1
19	9XXLG000152	Proximity switch frame	1
20	9XXLG000212	2650Siemens column welding parts	1
21	9XXLG000108	Switchboard	1
22	9XXLG000201	Trolley travel mechanism	1
23	JQTQT000005	Key of door	1
24	JQTQT000004	Door lock	1

2) Breakdown diagram of lifting car

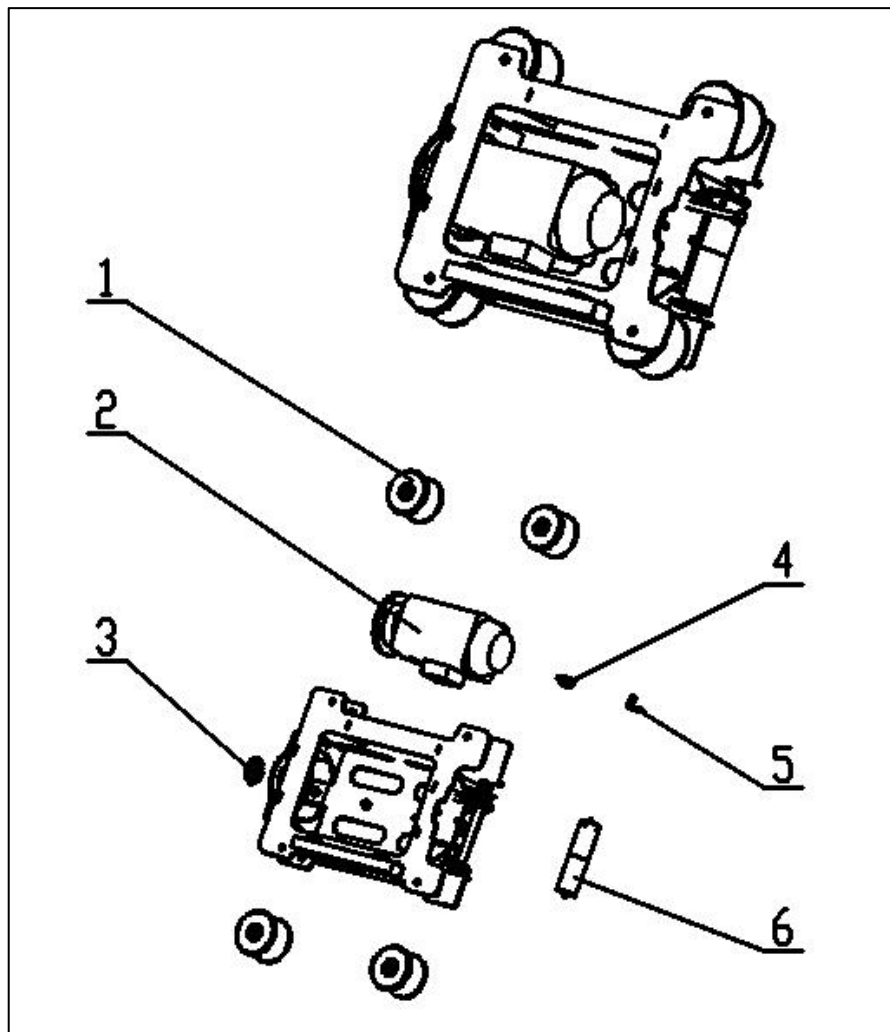

NO.	Workpiece number	Workpiece name	Quantity
1	9XXLG000141	Guide wheel assembly	4
2	JDJL000004	Lift car motor	1
3	9XXLG000200	Film carriage main power sprocket (18 teeth)	1
4	DKGJJ000001	Proximity switch (normally open)	1
5	9XXLG000214	Counting switch mounting bracket	1
6	9XXLG000135	Take-up wheel assembly	1

8.2.3 Film carriage exploded view and detail list

1)Exploded view of the assembly of the micro-movement film seat (with electromagnetic cutting)

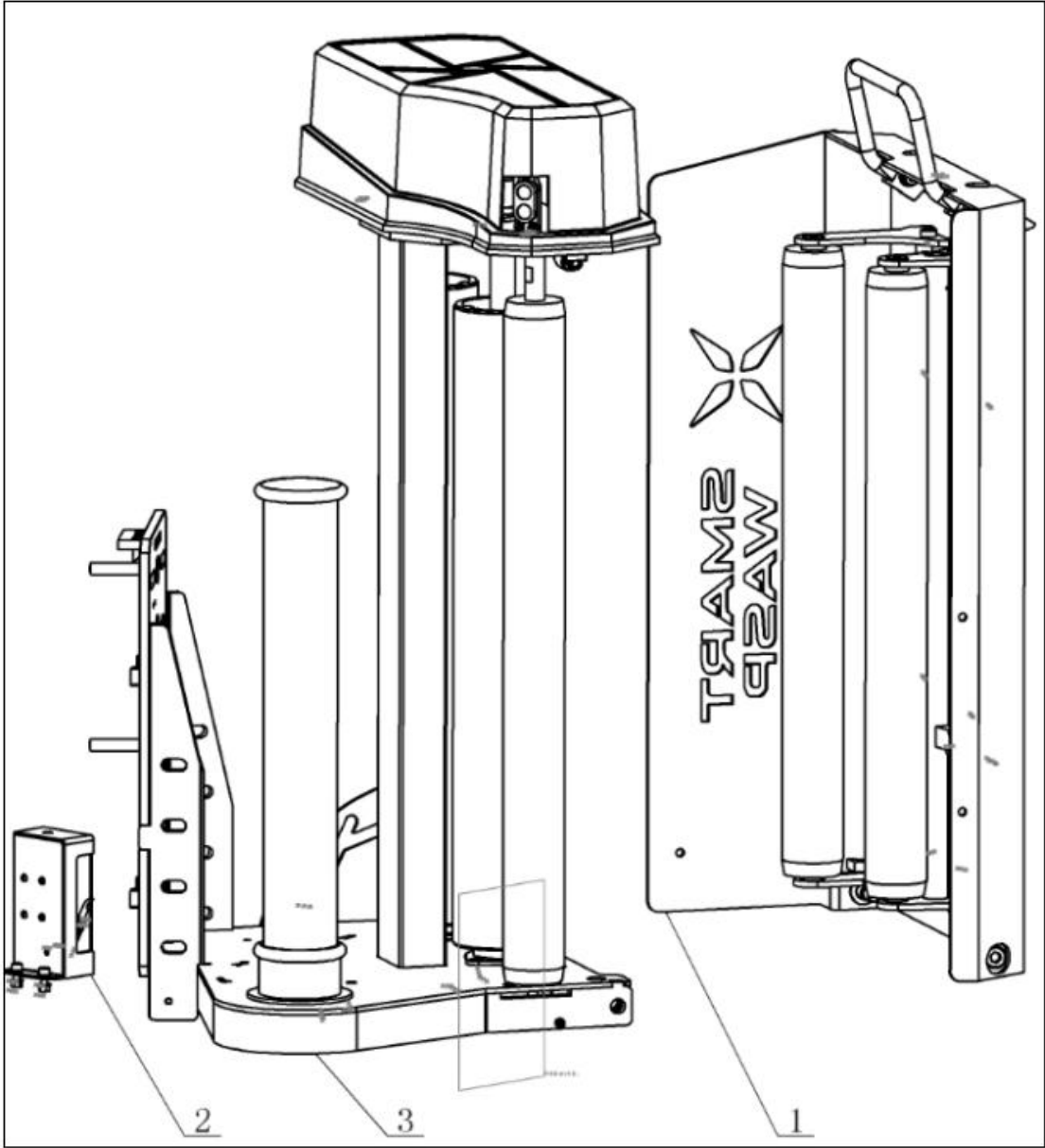

NO.	Workpiece number	Workpiece name	Quantity
1	9XXSD000100	Micro-movement film carriage door body	1
2	9XXSE00010	Film seat cutting module	1

3	9XXSE000111	Main frame of membrane	1
---	-------------	------------------------	---

2)Exploded view of the door body of the micro-movement membrane seat

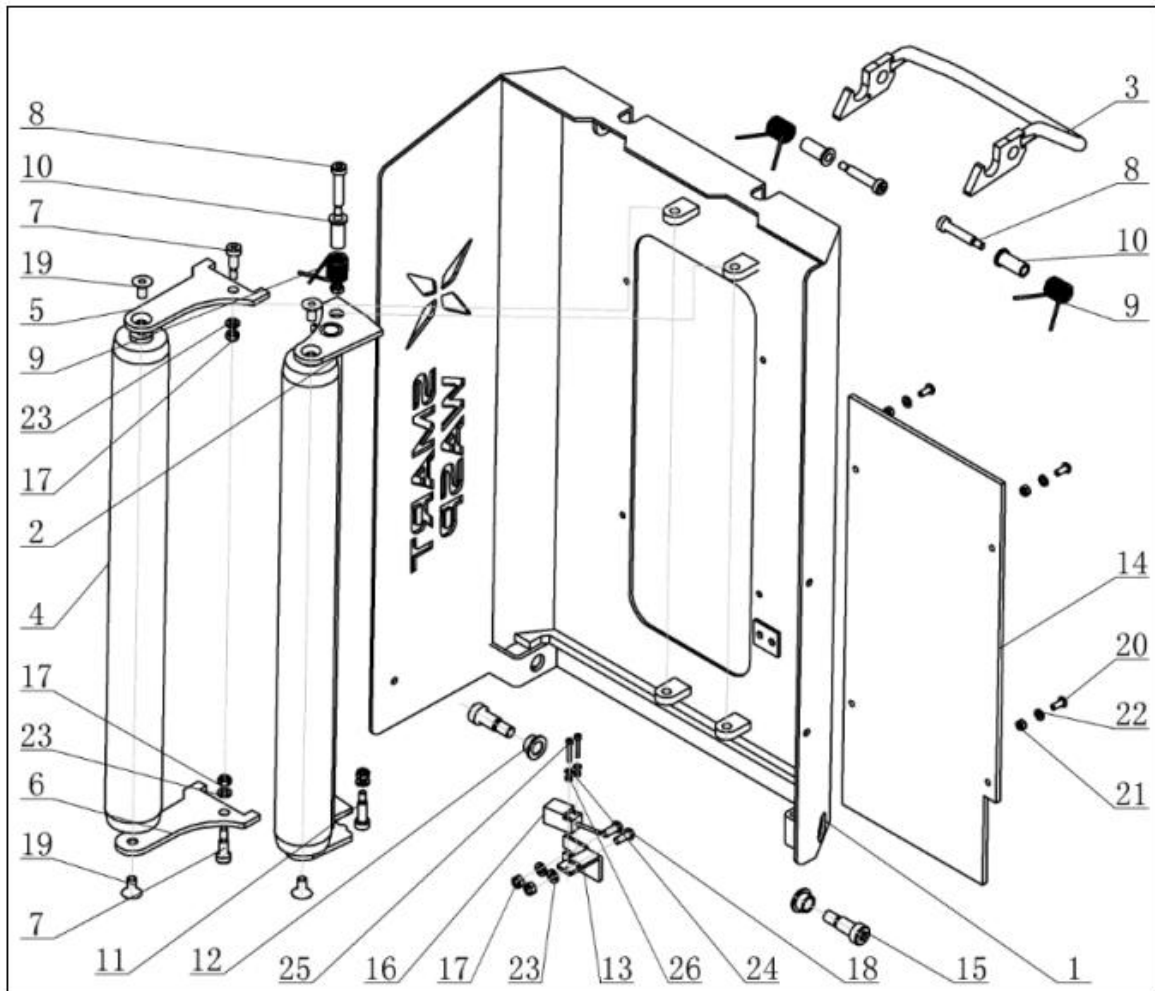

NO.	Workpiece number	Workpiece name	Quantity
1	9XXSE000106	Film carriage door	1
2	9XXSE000104	Micro-motion induction roller mounting frame	1
3	9XXSA000068	Film carriage door handle	1
4	9XXSA000071	Film seat guide film roller(L523)	2
5	9XXSE000102	Film seat guide film roll up fixing piece	1
6	9XXSE000103	Film seat guide film roll down fixed piece	1
7	JJGLD000289	Contour screw $\phi 8$ -L16-M6	2

8	JJGLD000225	Contour screw Φ 8-L35-M6	3
9	9XXSA000063	Door handle reset torsion spring	3
10	9XXSA000014	Handle shaft copper sleeve	3
11	JJGLD000224	Contour screw Φ 8-L20-M6	1
12	9XXSA000006	Door shaft copper sleeve	2
13	9XXSB000006	Proximity switch holder	1
14	9XXSA000062	Observation board	1
15	JJGLD000226	Contour screw Φ 12-L20-M10	2
16	DKGJJ000001	Proximity switch (normally open)	1
17	JJGLM000018	Lock nut M6	6
18	JJGLD000080	Hexagon socket flat head screw M6X16	2
19	JJGLD000152	Hexagon socket countersunk head screw M8X16	4
20	JJGLD000071	Hexagon socket flat head screw M5X12	4
21	JJGLM000026	Lock nut M5	4
22	JJGPD000001	Flat washer M5X1	4
23	JJGPD000002	Flat washer M6X1.6	5
24	JJGPD000006	Flat washer M3X0.5	2
25	JJGLD000039	Hexagon socket head screw M3X20	2

3) Exploded view of membrane seat cutting module

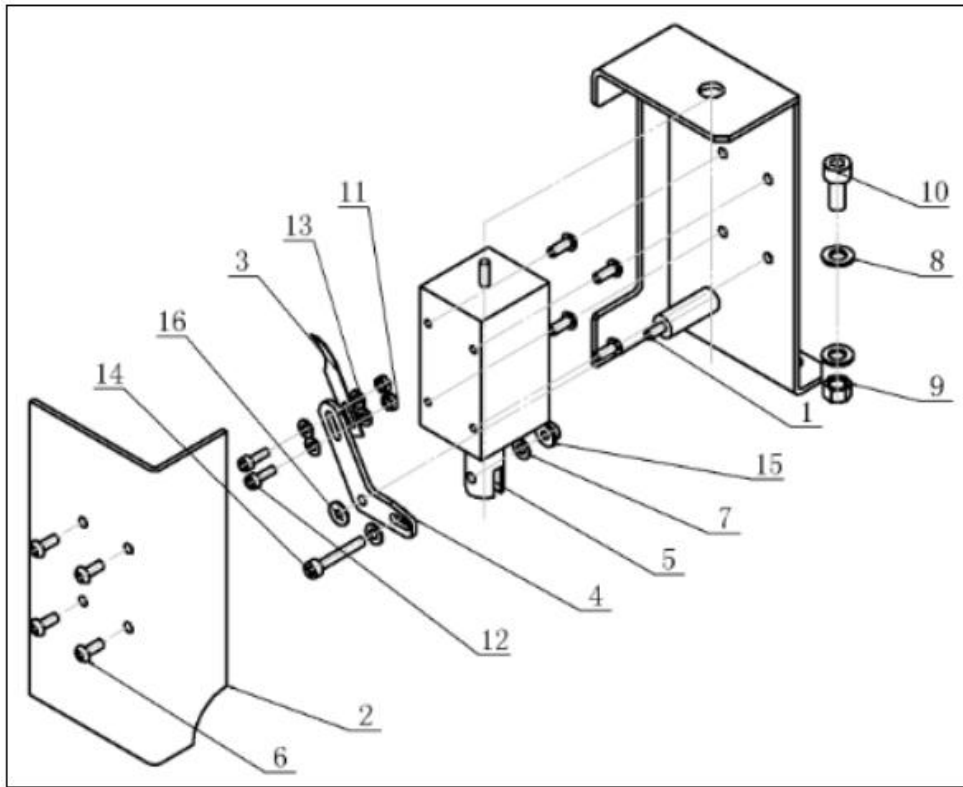

NO.	Workpiece number	Workpiece name	Quantity
1	9XXSD000012	Film carriage cutting bracket welding	1
2	9XXSD000003	Broken film cover	2
3	9XXSD000006	Broken film blade	1
4	9XXSD000002	Broken film connecting rod	1
5	JQTDC000001	Broken film electromagnet	1
6	JJGLD000062	Hexagon socket flat head screw M3X8	8
7	JJGPD000006	Flat washer M3X0.5	4
8	JJGPD000001	Flat washer M5X1	4
9	JJGLM000004	Hex nut M5	2
10	JJGLD000024	Hexagon socket head screw M5X12	2
11	JJGLD000240	Hex nut M2.5	2
12	JJGLD000239	Hexagon socket head screw M2.5×8	2
13	JJGPD000011	Flat washer M2.5×0.5	4
14	JJGLD000039	Hexagon socket head screw M3X20	1
15	JJGLM000021	Lock nut M3	1
16	JJGSJ000001	Internal tooth lock washer Φ2.5×0.3	1

4)Partially exploded view of film carriage main frame

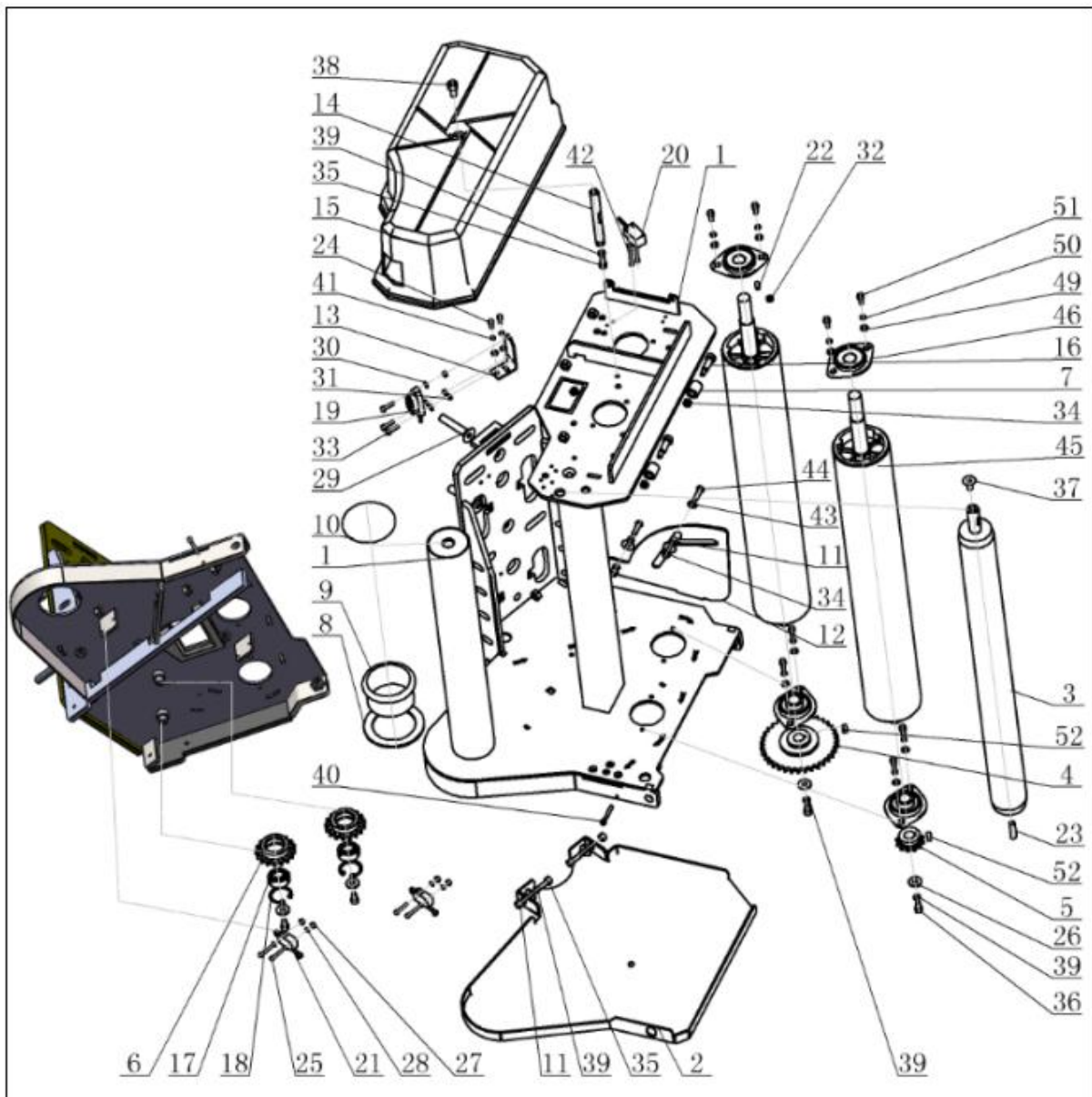

NO.	Workpiece number	Workpiece name	Quantity
1	9XXSE000112	Main frame and top plate welding	1
2	9XXSE000121	Safety board	1
3	9XXSA000138	Film seat film guide roller (L607)	1
4	9XXSA000058	Transmission from sprocket 1 (35 teeth)	1
5	9XXSA000127	Transmission from sprocket 2 (12 teeth)	1
6	9XXSA000041	Tension sprocket	2

7	9XXSA000061	Straight push mechanism roller	2
8	9XXSA000055	Film roll bottom gasket	1
9	9XXSA000056	Fixed sleeve under film roll	1
10	9XXSA000057	Film roll column top fixing piece	1
11	9XXSA000003	Door opening limit bushing	4
12	9XXSA000002	Door opening limit plate	1
13	9XXSA000134	Photoelectric switch bracket	1
14	9XXSC000003	Heightening membrane seat cover fixing column	1
15	9XXSC000009	New model membrane seat top cover	1
16	JJGLD000224	Contour screw $\Phi 8$ -L20-M6	2
16	JJGLD000224	Contour screw $\Phi 8$ -L20-M6	2
18	JDQKY000001	Retaining ring for hole D=30	2
19	DKGGD000001	Photoelectric switch	1
20	DKGJJ000001	Proximity switch (normally open)	1
21	DKGWD000001	Micro Switch	2
22	JJGLD000221	M5 top wire	1
23	JJGLD000230	Hexagon socket set screws with flat point M8 \times 30	1
24	JJGLD000027	Hexagon socket head screw M4X10	2
25	JJGLD000039	Hexagon socket head screw M3X20	6
26	JJGPD000009	Large washer M6X1.6	8
27	JJGLM000021	Lock nut M3	4
28	JJGPD000006	Flat washer M3X0.5	10
29	JJGLD000174	Hexagon socket countersunk head screws M10X5005	2
30	JJGPD000007	Flat washer M4X0.8	5
31	JJGLM000022	Lock nut M4	3
32	JJGLM000004	Hex nut M5	1
33	JJGLD000029	Hexagon socket head screw M4X16	3
34	JJGLM000018	Lock nut M6	3
35	JJGLD000002	Hexagon socket head screw M6X16	3
36	JJGLD000005	Hexagon socket head screw M6X10	4
37	JJGLD000152	Hexagon socket countersunk head screw M8X16	1

38	JJGLD000043	Hexagon socket head screw M8X16	1
39	JJGTD000004	Elastic washer M6X1.6	6
40	JJGLD000032	Hexagon socket head screw M4X30	1
41	JJGTD000002	Elastic washer M4X1.1	2
42	JJGTD000001	Elastic washer M3X0.8	2
43	JJGPD000002	Flat washer M6X1.6	2
44	JJGLD000244	Hexagon socket flat head screw M6×20	2
45	9XXSE000089	Little Hornet Film Roll	2
46	JZCDZ000048	Bearing with seat	4
47	JJGLD000236	Hexagon socket set screws with flat point M6×16	1
48	JJGLM000005	Hex nut M6	1
49	JJGP000001	Flat washer M5×1_1	8
50	JJGTD000003	Elastic washer M5X1.3	8
51	JJGLD000334	内六角圆柱头螺钉 M5×12_1	8
52	JJCPJ000001	Ordinary flat key-A type	2

8.2.4 Clamping and cutting film exploded view and schedule

1)Cut film frame

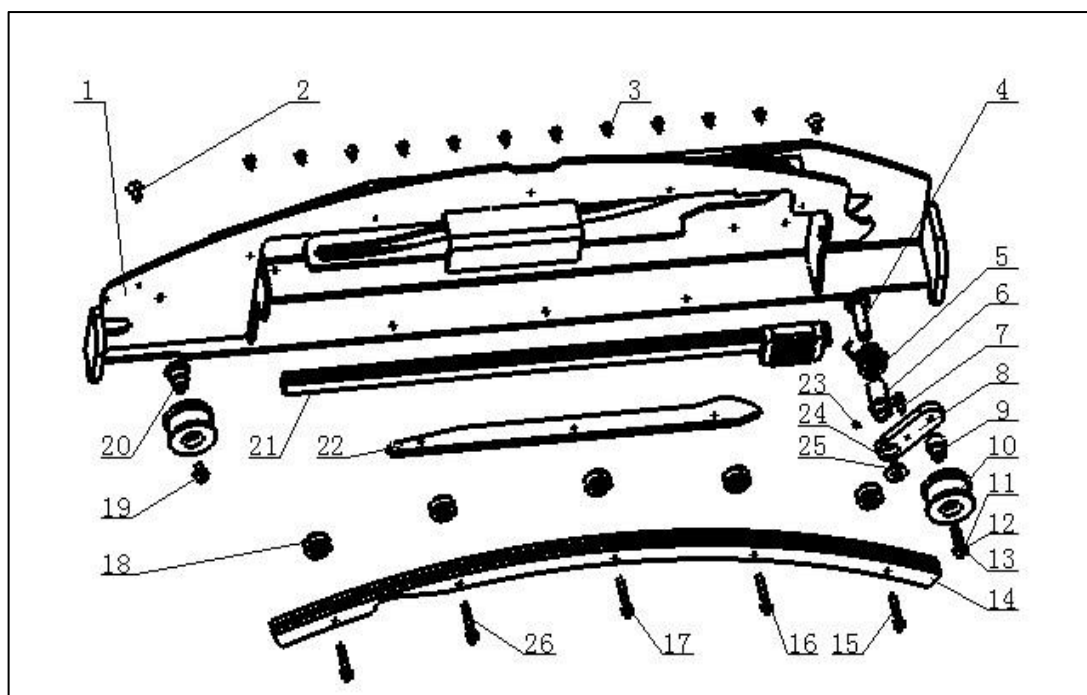

NO.	Workpiece number	Workpiece name	Quantity
1	9XXAA000055	1650 broken film frame welding parts	1
2	JJGLD000248	Hexagon socket countersunk head screw M8×16	2
3	JJGLD000253	Hexagon socket countersunk head screw M6×12	14
4	9XXAA000068	Belt tensioner fixed shaft	1
5	9XXAA000069	Tension torsion spring	1
6	9XXAA000070	Belt tensioning fixed sleeve	1
7	JJGLD000251	Hexagon socket head screw M6×16	1
8	9XXAA000071	Transition mounting plate	1
9	9XXAA000072	Belt tensioner fixed shaft	1
10	9XXAA000066	Pulley assembly	2
11	JJGPD000003	Flat washer M8X1.6	2
12	JJGTD000005	Elastic washer M8X2.1	2
13	JJGLD000252	Hexagon socket flat head screw M8×35	1
14	9XXAA000076	Belt chute	1
15	JJGLD000254	Hexagon socket head screw M6×40	2
16	JJGPD000002	Flat washer M6X1.6	5
17	JJGTD000004	Elastic washer M6X1.6	6
18	9XXAA000075	Custom bearings	5
19	JJGLD000249	Hexagon socket flat head screw M8×16	1
20	9XXAA000065	Belt fixed wheel installation shaft	1
21	JCDZX000002	Sliding track	1
22	9XXAA000074	Film guide plate	1
23	JJGLD000250	Hexagon socket set screw with cone point M5×8	1
24	JJGLD000244	Hexagon socket flat head screw M6×20	1

25	JJGPD000014	Enlarged flat pad $\Phi 6 \times 25 \times 2$	1
26	JJGLD000255	Hexagon socket head screw M6 \times 45	3

4) Broken film assembly

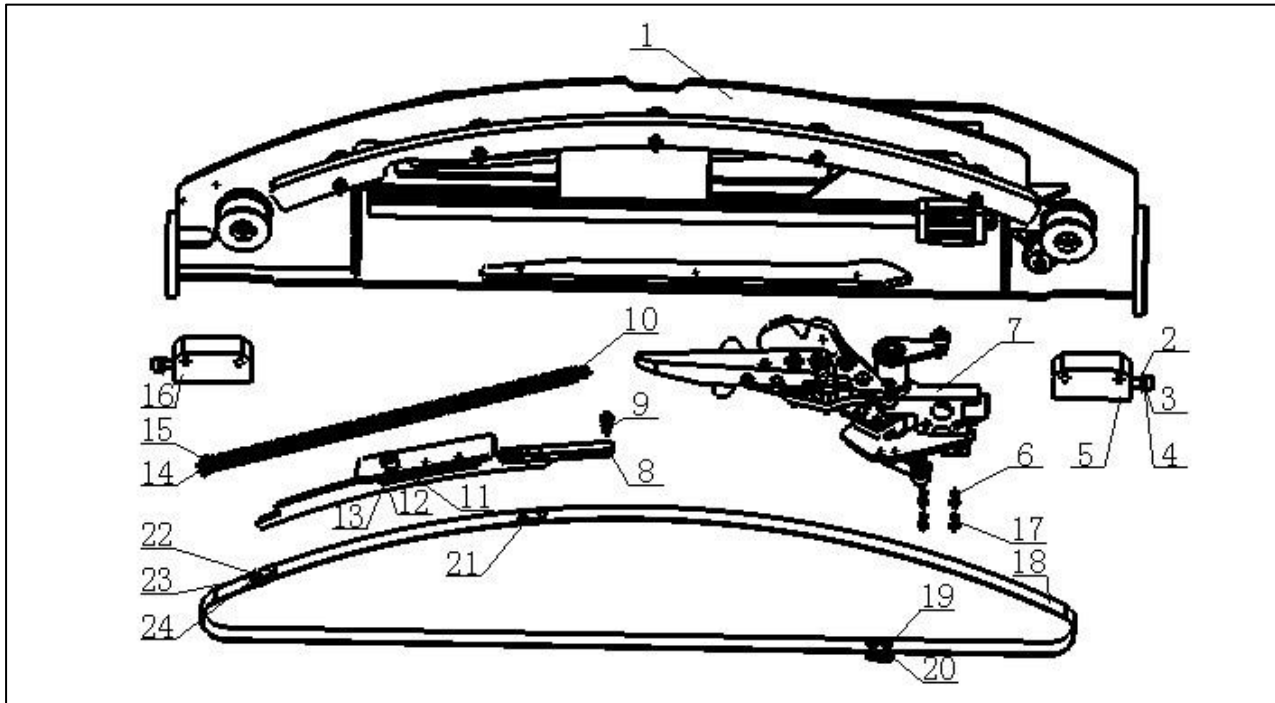

NO.	Workpiece number	Workpiece name	Quantity
1	9XXAA000053	1650 broken film frame assembly	1
2	JJGLD000264	Hexagon socket head screw M8 \times 30	2
3	JJGPD000003	Flat washer M8X1.6	2
4	JJGTD000005	Elastic washer M8X2.1	2
5	9XXAA000141	Device right fixed foot	1
6	JJGLD000268	Hexagon socket head screw M5 \times 16	4
7	9XXAA000004	Break film movement components	1
8	9XXAA000099	Reset connection board	1
9	JJGLD000247	Hexagon socket head screw M6 \times 20	1
10	9XXAA000111	Conversion belt reset tension spring	1
11	JZCGZ000001	Cam follower	1
12	9XXAA000139	Belt sliding rod welding parts	1

13	9XXAA000018	Broken film follower bushing	1
14	JJGLD000251	Hexagon socket head screw M6×16	1
15	JJGLM000005	Hex nut M6	3
16	9XXAA000112	Device left fixed foot	1
17	JJGTD000003	Elastic washer M5X1.3	6
18	9XXAA000080	Conversion belt	1
19	JJGLD000266	Hexagon socket head screw M5×12	2
20	9XXAA000114	Belt pressure pad	1
21	9XXAA000154	Belt press	3
22	JJGLD000256	Hexagon socket head screw M3×16	1
23	JJGTD000001	Elastic washer M3X0.8	1
24	JJGPD000006	Flat washer M3X0.5	1

8.3 Spare and wearing parts

NO.	Workpiece name	Workpiece number	Quantity
1	Cylindrical proximity switch	DKGJJ000008	1
2	Proximity switch (normally open)	DKGJJ000001	2
3	Microswitch	DKGWD000001	2
4	Bearing package nylon	9XXDI000073	19 sets
5	Film roll gasket	9XXSA000055	1
6	Film roll sleeve	9XXSA000056	1