



Instruction Manual



Smart Wasp

X0ps pallet wrapping machine

Catalogue

1 Basic Information.....	4
1.1 Manual purpose.....	4
1.2 This user manual.....	4
1.3 Agreement.....	5
1.4 Environmental protection.....	5
1.5 Machine identification.....	6
1.6 Additional help and information.....	6
2 Safety Instructions.....	7
2.1 Standards and directives.....	7
2.2 Safety regulations.....	7
2.3 Operational skills.....	11
2.4 Safety features.....	11
3 Technical Parameter Description.....	15
3.1 Composition of main components.....	15
3.2 Control panel.....	17
3.3 Working principle.....	18
3.4 Optional.....	19
4 Transportation And Installation Instructions.....	21
4.1 Transportation safety.....	21
4.2 On-site transportation.....	22
4.3 Temporary storage.....	23
4.4 Preparation before installation.....	23
4.5 Device installation.....	25
5 Instructions.....	30
5.1 Safety instructions.....	30
5.2 Operator tasks.....	30
5.3 Turn on the machine.....	30
5.4 Installation and replacement of stretch film.....	31
5.5 loading pallet instructions.....	32
5.6 Stretch film installation operation.....	32

5.7 Turn on device.....	33
5.8 Turn off the device.....	34
5.9 Touch screen homepage.....	34
5.10 Pause packaging cycle.....	36
5.11 Automatic operation stop (emergency stop).....	36
5.12 Return to origin.....	36
5.13 Manual operation.....	37
5.14 Administrator settings.....	37
5.15 Equipment status.....	37
5.16 Multiple choice interface.....	41
5.17 Parameter settings.....	43
5.18 Automatic operation.....	45
5.19 Alarm description.....	46
6 Care and maintenance instructions.....	47
6.1 Safety instructions.....	47
6.2 Preparation for maintenance.....	47
6.3 End of maintenance.....	47
6.4 Maintenance schedule.....	47
6.5 Check the function of safety facilities.....	48
6.6 Cleaning machine.....	48
6.7 Cleaning the rollers on the film carriage.....	48
6.10 Add lubricating oil to seated bearings.....	49
6.11 Check Turntable chain tension and lubricate.....	49
6.13 Checking the travel wheels of the Turntable.....	50
6.14 Check column chain tension and lubricate.....	51
7 Troubleshooting instructions.....	53
7.1 Safety instructions.....	53
7.2 Troubleshooting.....	53
7.2.3 Common mechanical faults and troubleshooting.....	58
8 Appendix.....	59
8.1 Electrical schematic.....	60
8.2 Exploded view and detailed list.....	65
8.3 Wearing parts.....	653

1 Basic Information

1.1 Purpose of the manual

This manual is intended to train professional users and operators. With the help of this manual, you will be familiar with the pallet wrapping machine and its optional features, enabling you to use, operate, manage and maintain the machine in a safe and effective manner.

Notice to users:

- The user must operate the machine in accordance with all safety instructions and procedures in this manual and all safety procedures in the work area;
 - Ensure that the machine is properly installed, commissioned, operated, and maintained, and that only adequate and properly trained personnel can perform these operations;
- Ensure that the machine is used in full compliance with the laws and regulations, which have legal effect.

1.2 This user manual

This manual is part of the equipment and this information will help the machine operate safely and efficiently.

 **Note**
Read this manual thoroughly before operating the machine or performing any procedures

1.2.1 Source content

The source language of this manual is Chinese. The source Chinese text will be legally binding to prevent any differences between the translated text and the source text. **The author of this manual is Smart Wasp Intelligent Technology (Suzhou) Co., Ltd., hereinafter referred to as Smart Wasp.**

 **Note**
As we continue to improve and develop our products, it is not always possible to provide true pictures of every detail of the machine. Therefore, the illustrations always show a typical standard machine.

1.2.2 Supplemental and other information

This manual has been carefully crafted based on our experience and the latest knowledge. Therefore, the information in this manual was valid and correct at the time of publication.

As we continue to improve and develop our products, modifications to the machine are part of internal procedures and you may receive supplemental and other information at a later date, including corrections or improvements.



Note

Incorporate these supplements into this manual to ensure that customers always have the latest version of the manual.

1.3 Agreement

This user manual uses the following conventions

1.3.1 Warning

This user manual uses the following warnings:



Warning

Identifies dangers that could lead to personal injury or even death.



Cautious

Identifies hazards that may cause machine failure or damage.



Note

Used to highlight additional information.



1.3.2 Printing and creation agreement

- Between bulleted lists and enums, always with bullets
- The steps must be performed in a prescribed sequence that is always numbered throughout the process.

1.4 Environmental protection

Please observe the disposal of used or replaced parts and materials in the tasks described in this document, and all recycling and disposal must comply with local environmental laws and regulations.

1.5 Machine identification

SMART WASP		Serial No.:	
Smart Wasp Intelligent Technology Co.,LTD			
Name	Model	Verison	Date
<input type="text"/>	<input type="text"/>	<input type="text"/>	<input type="text"/>
Voltage	Phase	HZ	Machine Size
<input type="text"/>	<input type="text"/>	<input type="text"/>	<input type="text"/>
Total Power	Max Load	Weight	Control Model
<input type="text"/>	<input type="text"/>	<input type="text"/>	<input type="text"/>
Air Requirment (PSI T BAR)		Air Requirment (CFM I /min)	
<input type="text"/>		<input type="text"/>	
SCCR		Max V	
<input type="text"/>	KA	<input type="text"/>	
Original			
Shanghai	<input type="checkbox"/>	Shenzhen	<input type="checkbox"/>
Suzhou	<input checked="" type="checkbox"/>	Beijing	<input type="checkbox"/>
Hot Line 400 6040 919			
			
View More			
http://www.smartwasp.com			

1.6 Additional help and information

Wasp is committed to providing the highest level of support for its users and operators. Depending on the product, the support provided mainly includes:

- Training
- Service Management System
- 24-hour global support
- Maintenance agreement
- Tool Services
- Repair and renovation

If you need more help, please contact Wasp for more help

2 Safety instructions

2.1 Standards and directives

The machine is designed and manufactured in accordance with the requirements of the Machinery Directive [2006/42 / EC](#) and the legal requirements applicable at the date of construction:

- Machinery Directive:[2006/42/EC](#)
- Low Voltage Directive:[2014/35/ EU](#)
- EMC Directive:[2014/30/EU](#)

The machine is designed with safety in mind and includes features that help prevent injury and damage. However, all powerful machines can be dangerous if not used properly.

2.2 Safety regulations

2.2.1 General safety instructions

•The tasks described in this manual are only for personnel who are appropriately trained, have the required skill level (see section 2.3), and are familiar with all safety instructions and regulations mentioned in this manual.

•We do not accept any liability for any damage or personal injury caused by failure to follow the safety instructions in this document or the warnings, cautions, and cautions described in this manual.

•Depending on the specific working conditions in your work area, additional safety instructions may apply. Since we cannot directly control these specific working conditions, it is the responsibility of the user to ensure compliance with local environmental and safety regulations. If you handle an unsafe situation that is not described, please notify us immediately.

The machine may also contain third-party components. For specific safety instructions for these third-party components, consult the appropriate manual.

•Ensure that children and other unauthorized persons cannot enter the work area.

•Make sure there is sufficient light and ventilation in the work area.

•Dress correctly. Do not wear loose clothing. Remove jewelry, watches, etc. to prevent them from getting caught in moving parts.[People with long hair should wear safety helmets.](#)

• Please wear personal protective equipment (eg protective clothing, protective shoes, gloves, hard hat, goggles, ear muffs) according to the user's use environment.

- Before performing any tasks on the machine, check that the machine is safe and **that there are no obstacles around the device.**
- Always be vigilant and pay attention to your actions. Do not work on the machine when you are tired or drinking or taking medicine.
- Do not modify the structure of the machine. See section 2.2.5.
- Unless authorized, do not open the power distribution cabinet.
- Unless authorized, do not bridge, temporarily cancel or disable the machine's security features.

2.2.2 Instruction manual use

- Keep this instruction manual in a safe place near the machine. Ensure that the manual is always accessible.
- Please read this instruction manual thoroughly before using the machine or performing any of the tasks described. Make sure you always have the latest version of this instruction manual.
- **When reading the manual, read it in order to ensure that you can fully understand the contents of the operation manual.**

2.2.3 Decals and instructions on the machine

- The decals or instructions installed on the machine are part of the security features provided. They must not be covered or removed, and they must be clearly visible throughout the life of the machine.
- Damaged or illegible decals and instructions must be replaced immediately.

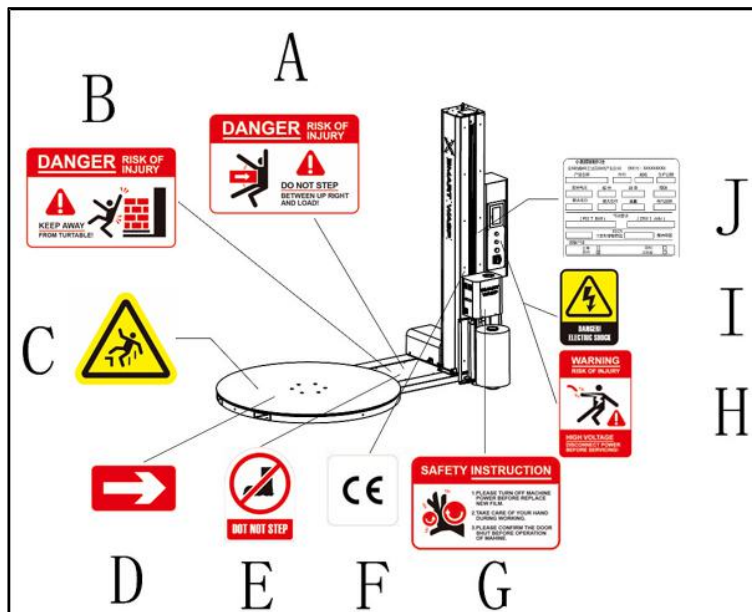

A Warning: danger of crushing, do not enter during operation

B Warning: Be careful when the machine is rotating

C Danger: Beware of Falling

D Warning: Turntable rotation direction

E Warning: Do not step on

F Indication: CE mark

G Warning: Do not reach into the film roll

H Warning: Non-professionals are forbidden to operate the electrical cabinet, there is a danger of electricity

I Warning: Power must be turned off before servicing

J Instruction: Machine identification plate

K Warning: be careful

2.2.4 Modify

Warning



Do not attempt to make any modifications or alterations to the machine without the prior express consent of the smart wasp. Unauthorized modification or alteration of the machine can cause serious personal injury or even death

Smart Wasp are always willing to turntableuss the issue of improving the value of the machine for users by modification or change. See section 1.6

2.2.5 Guarantee

•The machine has a 12-month warranty after installation, excluding components and electrical components that would wear out during normal use. The customer must notify the smart wasp of the defect and the machine serial number.

•Smart Wasp is not responsible for accidents or delays in production. When the customer adjusts the machine with components that are not recommended by the smart wasp, the smart wasp cannot guarantee that the machine meets EC requirements

.2.2.6 Security-transport

Note



Usually the machine is transported by the wasp or with the help of the instructions provided by the wasp. When moving the machine, please observe the safety instructions provided in Chapter

4.2.2.7 Security-install

Note



Usually the machine is installed, adjusted and commissioned by the manufacturer's professional, or with the help of the manufacturer's instructions.

When moving the machine, please follow the safety instructions provided in Chapter 5.

2.2.8 Safety-operation

- Please observe the general safety instructions. See section 2.2.1.
- Make sure that the machine and its surroundings are kept dry.
- Keep away from moving parts.
- Do not stand on the turntable even if the machine is turned off.
- Do not touch the area between the turntable and the floor of the machine (danger of crushing your fingers).
- When the machine is running:
 - Do not touch the pallet
 - Keep away from the area between the pallet (may be caught by the film roll and pallet).
 - Do not try to stop or drag the pallet manually, use the emergency stop button
- Always wear personal protective equipment specified or recommended by the user.
- During operation, the film carriage moves up and down. Keep away from the Film carriage pallet carriage (risk of crushing fingers-risk of foot injuries).

2.2.9 Security-maintenance

- Please observe the general safety instructions. See section 2.2.1.
- Before starting any maintenance (or even cleaning):
 - Set the main switch to the "OFF" position (0).
 - turntableconnect the power plug from the power outlet.
 - Wait for at least two minutes.
- Do not clean the machine with water (danger of electric shock)
- Do not use solvents to **clean** the machine. Use only a dry cloth and mild detergent to clean the machine.
- If the safety function is bridged or (temporarily) disabled, the safety function is reactivated or enabled immediately after maintenance work is completed. Before cleaning the machine for production, be sure to check the normal functioning of the safety functions.
- Do not leave anything inside or on the machine.
- The detection range of the sensor has been set by the manufacturer. Do not change this setting.

2.2.10 Safety-repair

- Please observe the general safety instructions. See section 2.2.1.
- Before starting maintenance work:
 - Set the main switch to the "OFF" position (0).

- turntable connect the power plug from the power outlet.
- Wait for at least two minutes.
- If the safety function is bridged or temporarily disabled, the safety function is reactivated or enabled immediately after the repair work is completed. Before cleaning the machine for production, be sure to check the normal functioning of the safety functions.
- Do not leave anything inside or on the machine.

2.3 Operational Skills

2.3.1 operator

- Only permitted operators should work on the machine.
- All operators can only perform their trained and executable operations.
- All operators who use or work on the machine must be familiar with the operating instructions.
- Operators must be familiar with everything that can happen so that they can act quickly and efficiently in emergency situations.
- This machine is only suitable for persons over 16 years of age. The corresponding national occupational safety and health regulations must be observed.

2.3.2 Operator skills

Operators are trained to:

- Loading and unloading pallets.
- Use the controls on the control panel to control the machine.
- Parcel pallet.
- Ready to load and unload the film roll.



Note

It is the responsibility of the user to ensure that machine operators are adequately trained in their operational tasks before commencing work.

2.4 Safety features

2.4.1 Overview of safety functions

The turntable packaging machine has the following safety functions:

- Emergency stop button (see section 2.4.2)
- Security stickers and instructions (see section 2.2.3)

- Film carriage anti-fall protection switch (see section 2.4.3)
- Ground wire (see section 2.4.4)
- Anti-fall lock (see section 2.4.5)

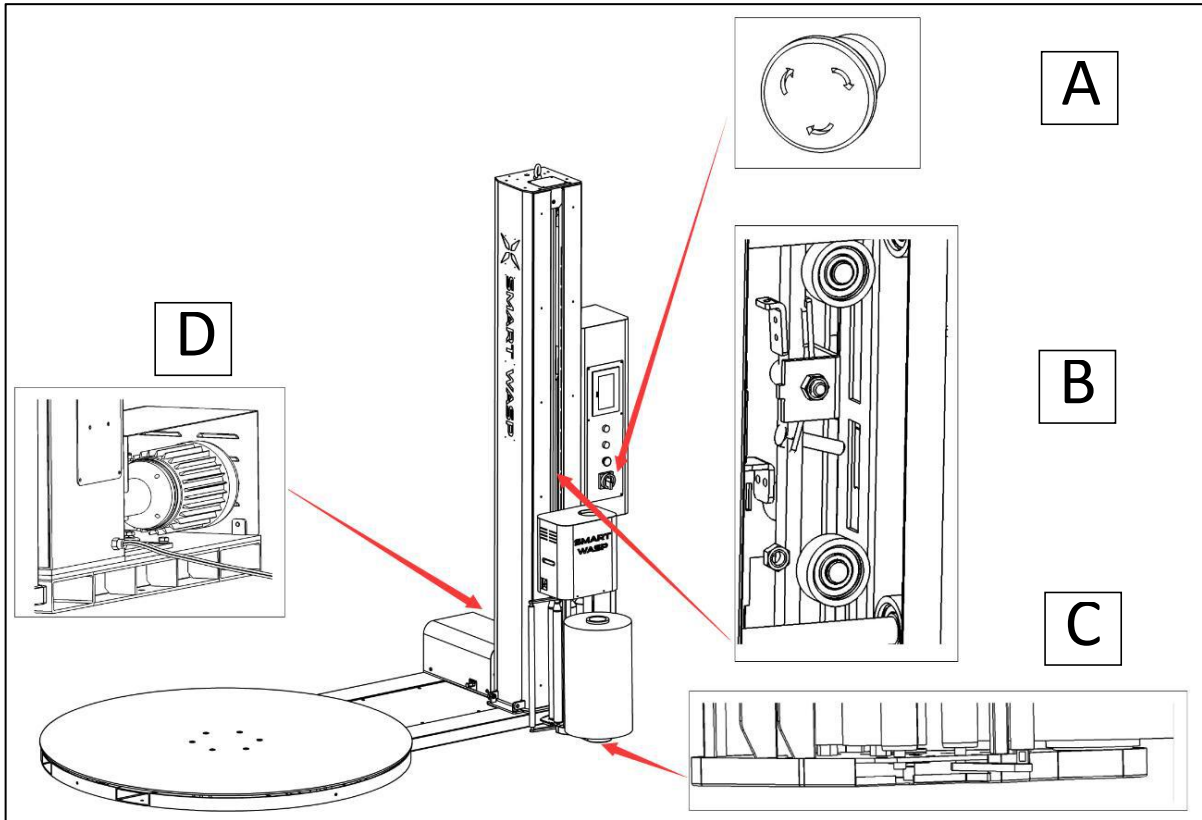

- A emergency stop button
- B Anti-fall lock
- C Anti-fall protection switch
- D Ground wire

2.4.2 emergency stop button

Emergency stop button is located on the control panel



Note

In an emergency, press the emergency stop button. The emergency stop button can be released by turning the emergency stop button clockwise

2.4.3 Film carriage anti-fall protection switch

The film carriage anti-fall protection switch is located under the film carriage. Once the lower cover touches the protection switch, the machine will stop

2.4.4 Ground wire

The electrical system is grounded. For the ground wire, the continuity test was performed after the smart wasp was commissioned. When leaving the factory, insulation tests and insulation strength tests are performed on electrical systems.

2.4.5 Anti-fall lock

When the chain breaks accidentally, the anti-fall protection system can effectively stop the Film carriage effectively to prevent falling.

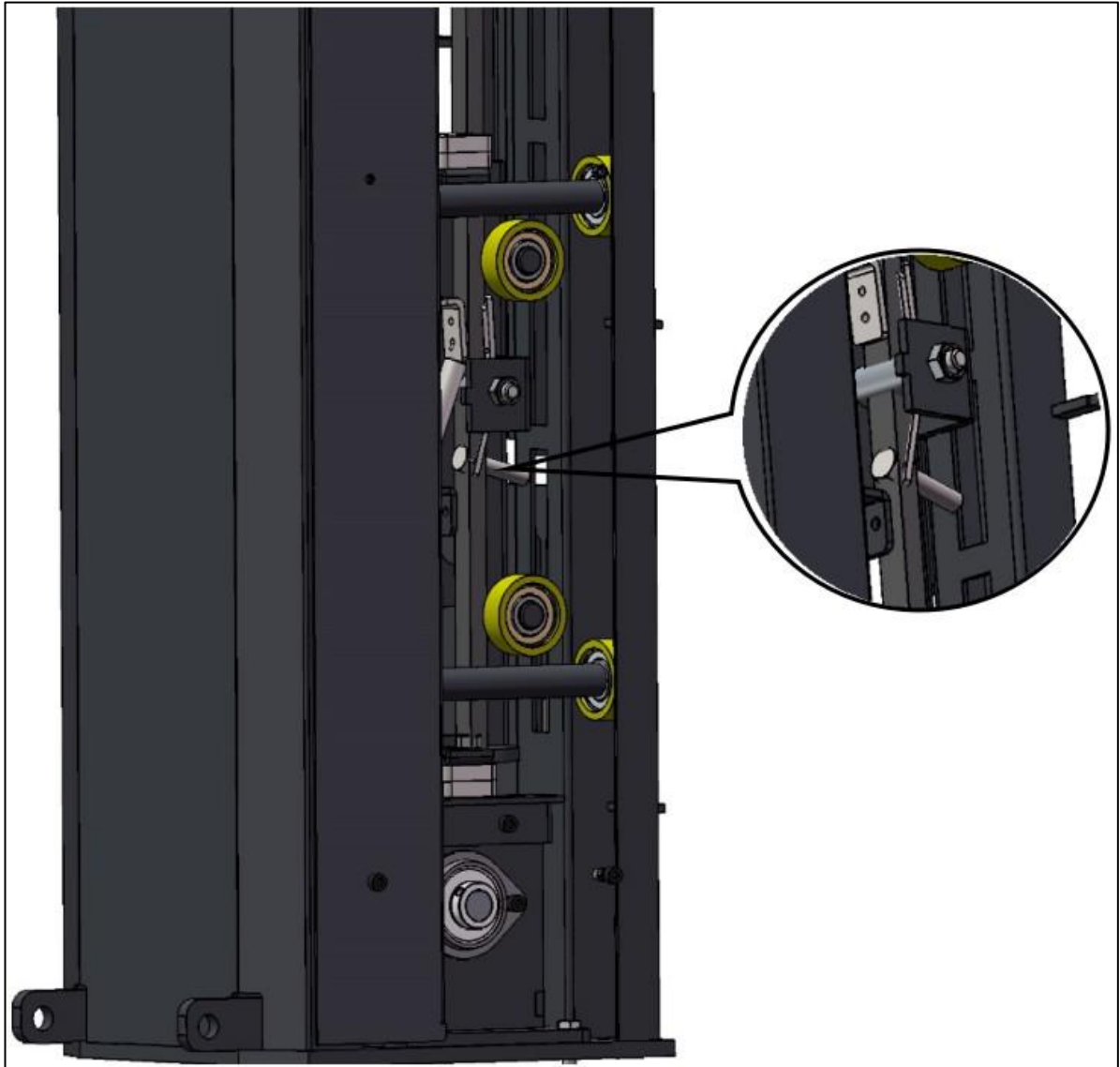

2.4 Major operational risk safety warnings

Operators must pay attention to the following safety warnings during the normal operation of the equipment:

•Danger of body collision and carryover:

Do not touch the machine parts while the machine is running

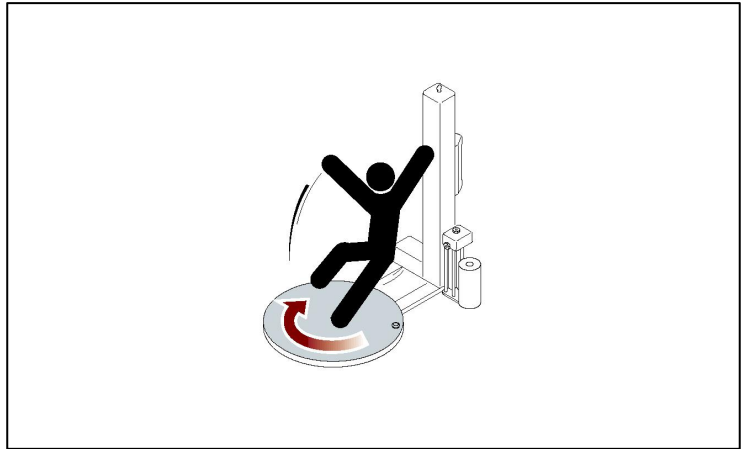

•No stay:

Do not stay in the operating area of the machine

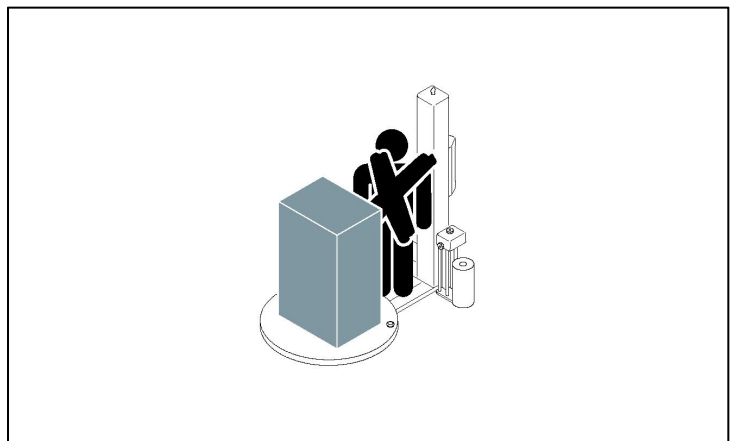

•Film carriage collision hazard:

Do not stand under the Film carriage

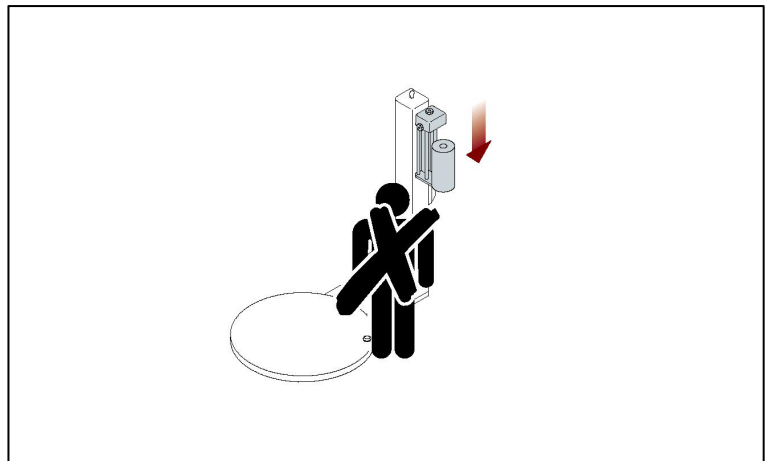

- Danger of collision during start up:
Do not stand turntable items when starting
Nearby to avoid danger

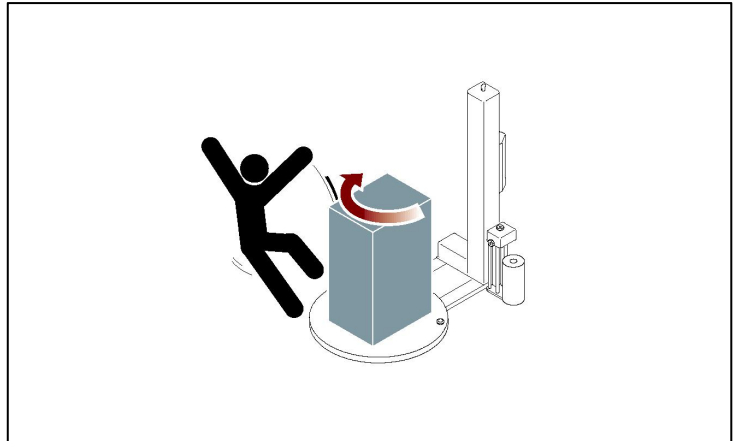

- Other dangers during start up:
When moving goods at start up
Forklift away from machine cargo

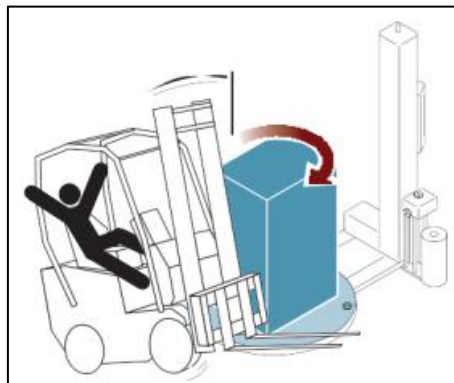

3 Technical parameter description

3.1 Composition of main components

X0ps standard pallet wrapping machine uses stretch film to pack pallet goods. The wrapping film can be evenly attached to the pallet goods in the pre-stretch mode. Its main components are shown in the figure below.

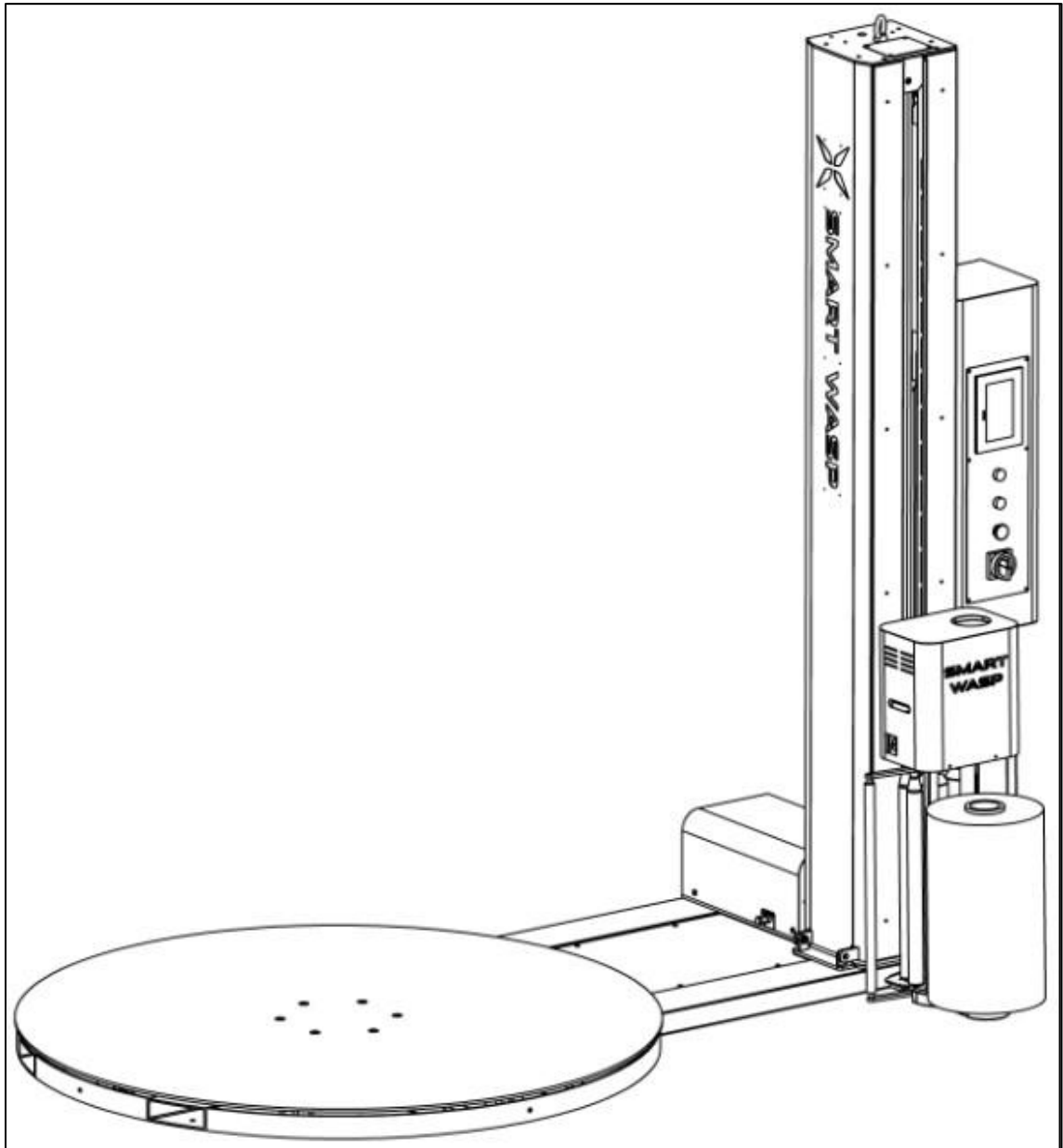

- A Tower
- B Electric control box
- C Film carriage
- D Turntable

3.2 Control Panel

3.2.1 Main control panel

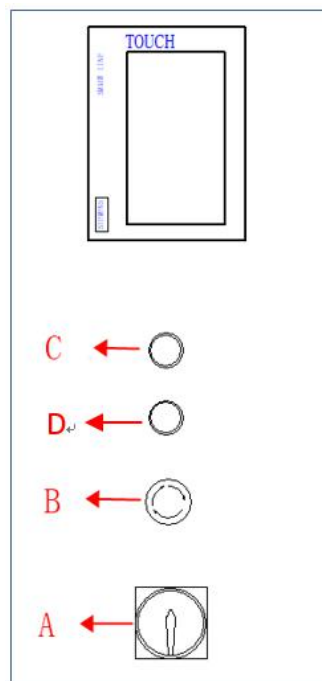

Number	Description	Features
TOUCH	Touch screen	The touch screen is used to operate the equipment and set the operating parameters. Refer to Section 5.7
A	Main power switch	Turn the main switch clockwise to power on the device; turn the main switch counterclockwise to the power port on the device.
B	Emergency stop switch	Press the emergency stop switch, the device will immediately stop running under any state; turn the button clockwise to release the emergency stop switch.
C	Power Indicator	When the main power switch is turned on, the power indicator is on.
D	start up button	Operate the start button and the device starts to run automatically

3.2.2 Sensor location

The icon below shows the information of the sensor position of the device and the access system, which is convenient for maintenance.

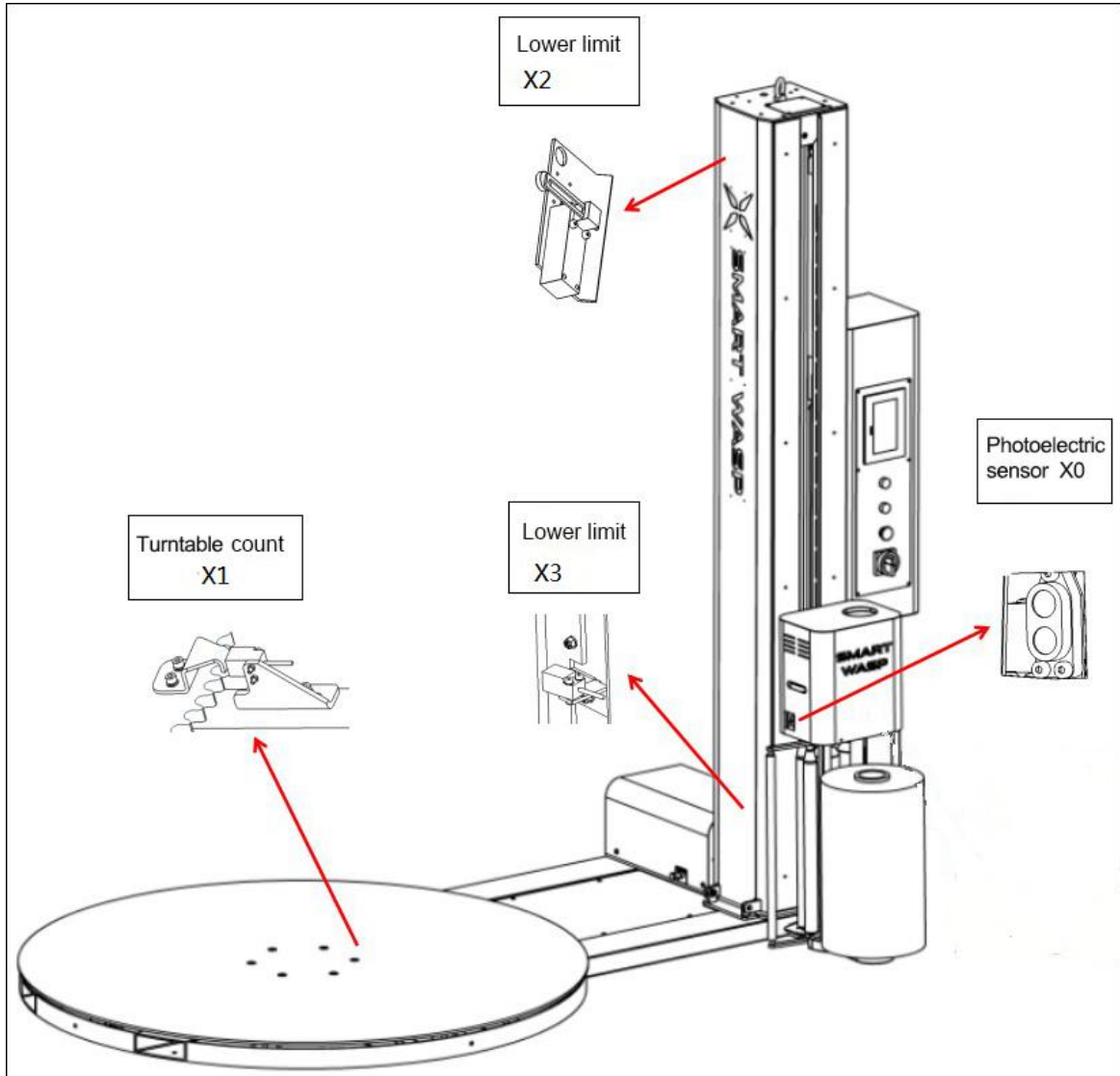

3.3 Working Principle

The operation of the X0 standard wrapping machine can be completed by an operator. Its basic working principle is as follows:

1. The goods are transported to a standard wrapping machine by a forklift, the film roll is loaded and the film head is manually attached to the surface of the goods (see 5 operating instructions for details);
2. Start the wrapping machine, and the goods will start to rotate from the initial

position (origin) with the turntable. At the same time, the film carriage at the bottom cooperates with the Turntable to release the film, and the film is wrapped on the goods under the rotation of the Turntable

3. According to the packaging requirements of different goods, the film starts to rise after wrapping a certain number of turns at the bottom of the goods, and the overall movement of the goods is realized by the combination of the rising motion of the film carriage, the rotation of the Turntable and the film exit motion of the film carriage;
4. When the film runs to the top of the cargo, it starts to descend after completing the top wrapping under the action of the photoelectric sensor;
5. When the film carriage runs to the bottom, the turntable starts to decelerate, and stops after completing the number of turns at the bottom to complete the wrapping;
6. After the film breaking is completed, a packing cycle ends, and the machine is in a standby state, waiting for the next packing of the goods.

3.4 Optional

3.4.1 Pit configuration

Note



According to the site conditions of different users, the working surface of the equipment is parallel to the working surface of the Turntable, and the pit is optional to facilitate the use requirements of specific customers.

3.4.2 Ramp configuration

The ramp is available as an option for specific customer requirements.

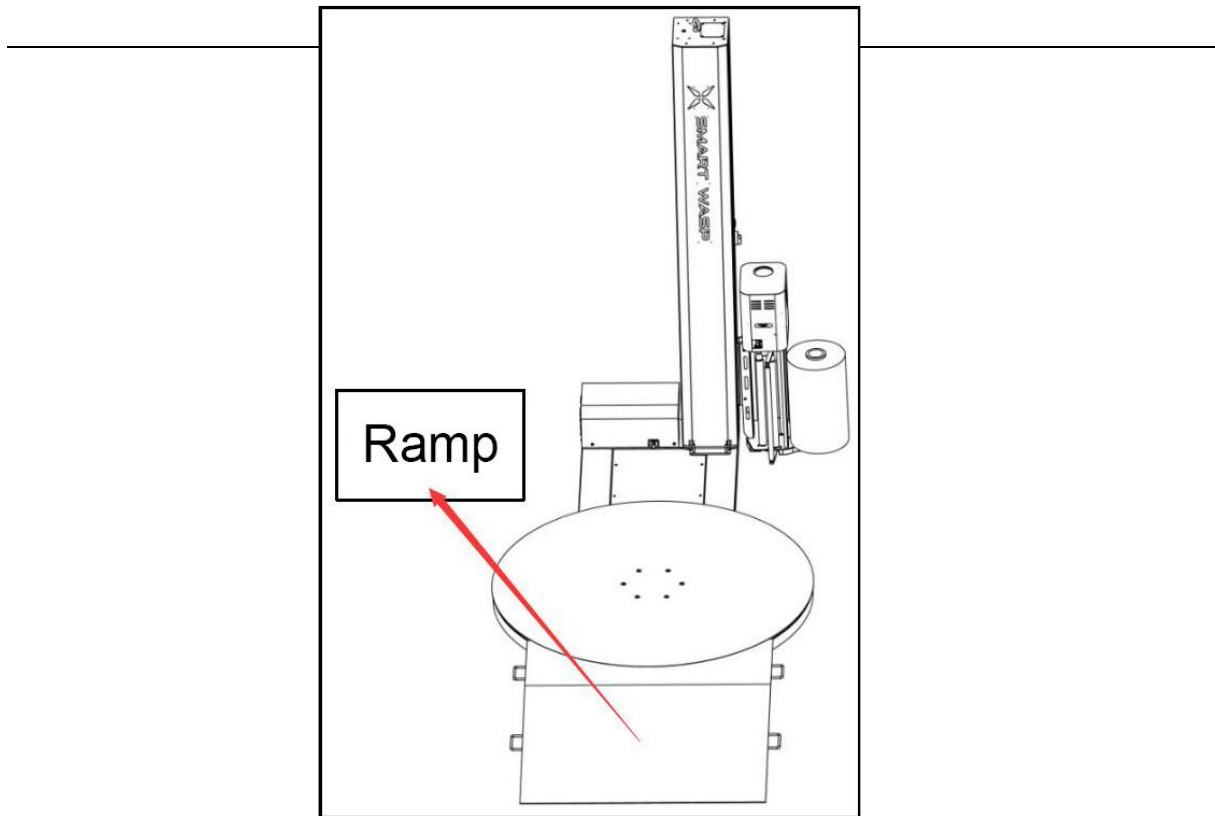

3.5 Technical Parameters And Main Configuration

3.5.1 Institutional parameters

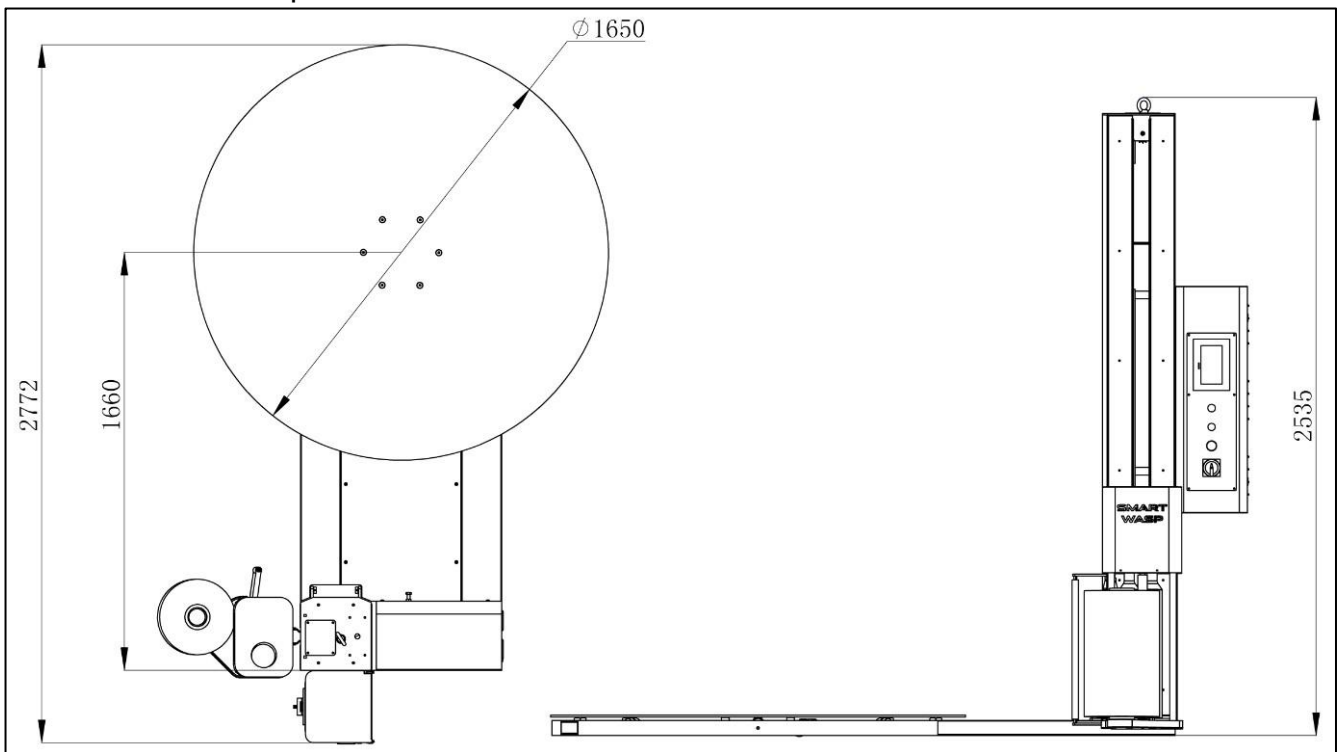

Model	X0	Machine size	See above
Brand	Smart wasp	Film roll thickness	14mic
Film roll width	500 mm	Film roll diameter	250mm

Film exit method	Power pretension	Standard pre-stretch ratio	200%
Packaging speed	30 Torr / hour	Intelligent AV sensor	standard
Packaging height	2000mm	Packing weight	1500Kg
Turntable speed	0-12RPM (adjustable)	Film carriage lifting speed	0-5.5m / min (adjustable)
Turntable size	Optional	Automatic film cutting	no
Machine weight	620Kg (重量错误)	Filming method	Manual
Weighing integration	Optional	Product tightness	Adjustable

3.5.2 Electrical parameters

Machine voltage	220V-240V / 50 / 60Hz single phase	Switchboard power	1.5Kw
PLC	SMARTWASP(X-LINE)	HMI	Siemens (SMARTWASP)
Motor	SMARTWASP	Inverter	SMARTWASP(X-LINE)
Contactors	Siemens	sensory switch	Germany SICK

3.5.3 Working environment parameters

temperature range	0°~ +40°	Humidity range	≤70% (relative humidity)
noise	75dB	Pneumatic environment	no

4 Transportation And Installation Instructions

4.1 Transportation safety



Note

1、 Please note that for the transport of the machine, follow the general safety practices and the safety instructions given in this section.

2、 Packaging materials consist of plastic film, plywood, etc. (please follow the relevant recommendations or regulations for the disposal and recycling of local packaging materials)

3、 Pay attention to waterproof and severe vibration during transportation.

4.2 On-site transportation



Note:

No need to disassemble the machine, the machine can be moved as a whole

- 1、 Turn on the power and move the film carriage up a distance (see 5 operating instructions for details)
 - a. Turn the main switch clockwise to turn on the machine
 - b. Click the touch screen to enter the password to enter the host interface
 - c. Select manual mode
 - d. Click the film carriage to rise, stop after rising to a suitable height
- 2、 Turn the main power switch counterclockwise to turn off the machine

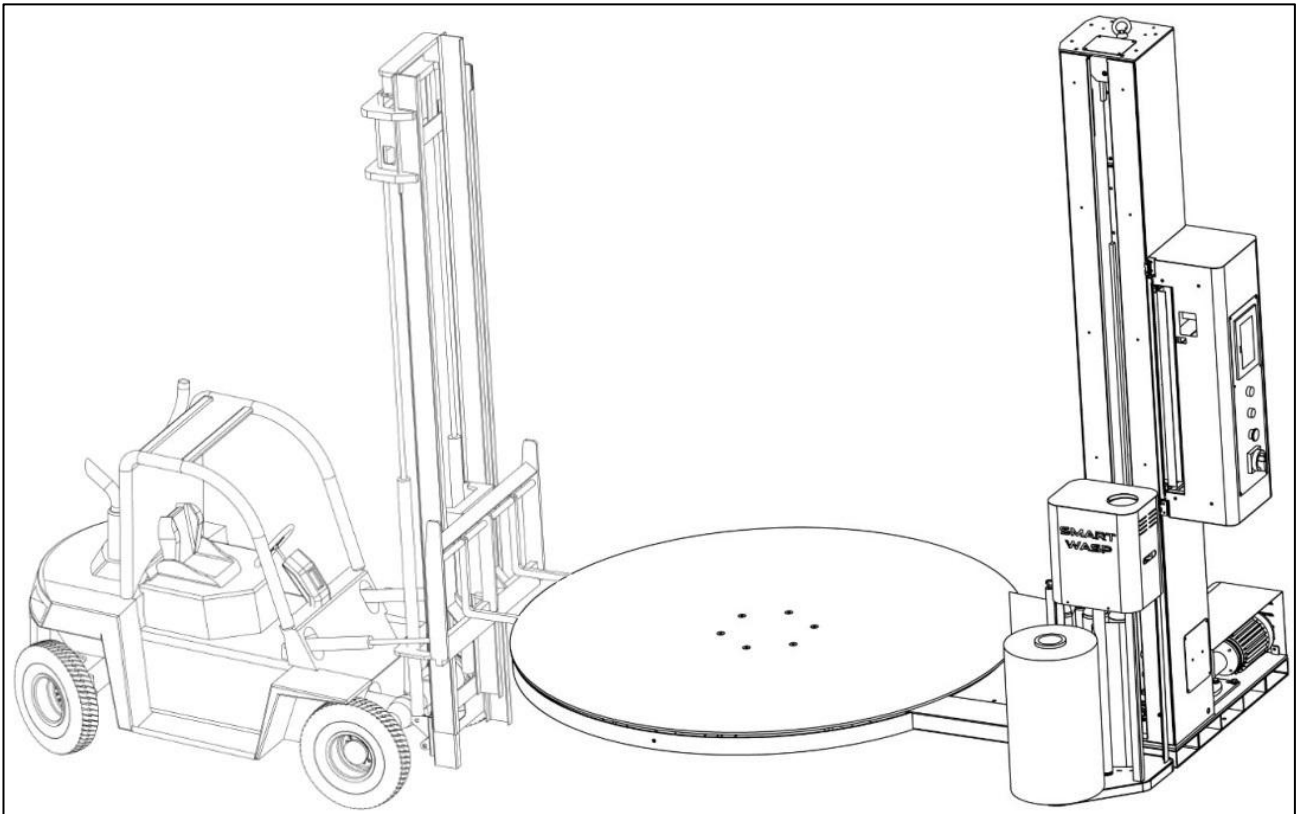

- 3、 Press the emergency stop button
- 4、 Remove the power plug from the power outlet

5、 Insert the fork teeth of the forklift into the bottom of the machine and raise the machine by about 50mm

6、 Move to a new location



Cautious

During transportation, pay attention to the obstacles on the top of the machine and the obstacles on the floor, such as the sink.

4.3 Temporary storage

If the machine must be temporarily stored, follow these steps

1. Protect the machine from dust
2. Store the machine in a clean, dry place. The environmental conditions required for installation also apply to storage.
3. Do not place anything on top of the machine.

4.4 Preparation before installation

Please read the entire installation section before you begin, and then follow the instructions step by step.

Cautious



(1) Complete each step before moving on to the next step!

(2) The device has multiple safety protection measures. When operated in the correct way, it can ensure safe operation. Please observe all safety signs. Do not turn on the power until the installation is complete.

(3) The device has multiple safety protection measures. If you operate it in the correct way, you can ensure safe operation. Please observe all safety signs. Do not turn on the power until the installation is complete.

4.4.1 Area preparation

The installation area of this equipment must meet the following space requirements:

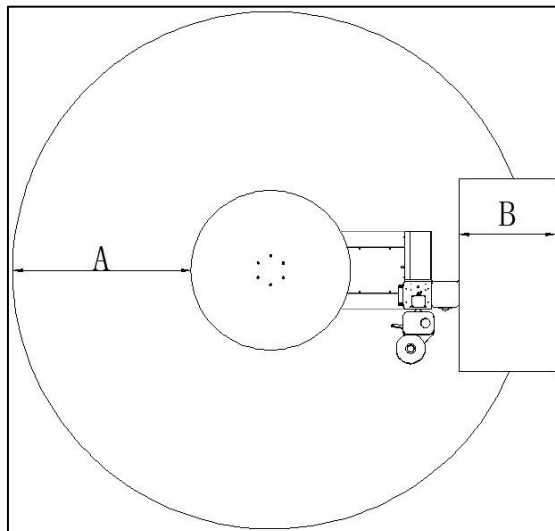

A 2000mm

B 1000mm

•Leave some space around the machine for daily operation, maintenance and repair

•In order to achieve the best operating condition of the machine, place the machine on a flat surface, if necessary, level the machine with a gasket.

4.4.2 Ground confirmation

The ground must be able to support the weight of the equipment, its maximum load and its impact, which requires:

Ground bearing capacity \geq (total weight of equipment + weight of goods) \times 1.5.

4.4.3 Electrical confirmation

System requires a dedicated single-phase grounded power supply:

220V/AC; 10A; 50/60Hz; 1PH



Note

For specific electrical requirements, see the equipment identification label or electrical drawing.

Cautious



(1) Use of extension cords and any other changes may cause damage to the circuit or affect the performance of the equipment, and may void the warranty. If you need to change, please call after-sales service.

(2) To avoid damage to the equipment, check the voltage in the electrical drawings before starting the equipment.

4.4.4 Equipment, tools and personnel requirements:

- Standard wrapping machine
- One set of tools (in the random toolbox), one forklift
- 1-2 mechanical / electrical technicians, 1 user

4.4.5 Equipment loading and unloading

(1) Loading and unloading of the main body (Turntable and three-dimensional part lying on it):

Equipment for main body loading and unloading: forklift.

Operation method: remove it through the forklift action port and transport it to the installation place to straighten it.

(2) Other parts:

Before moving the loading and unloading main body, other parts must be manually moved.

4.4.6 General hardware tightening torque reference

The torque and performance specifications of the fasteners provided and recommended for this product are shown in Table 4.1.

Table 4.1

Metric fastener torque comparison table		
Nominal size of fastener	Performance level	Torque (Nm)
M6	8.8	14
M8	8.8	24
M10	8.8	54
M12	10.9	102

4.4.7 Installation conditions

Humidity≤70% Temperature 0-40 °C

4.5 Device installation

4.5.1 Equipment installation preparation

- (1) Use a forklift to move the equipment to the installation area, remove the outer packaging, strapping materials and items used to fix the equipment;
- (2) Take out the random tools, check whether the equipment is complete, and arrange them neatly;

4.5.2 Post installation

- (1) Stand tower, pay attention to safety during operation

Before installation, the pillars are placed on the surface of the Turntable with a wrapping film or other soft material, and the pillars are erected. During the erection process, avoid collision and impact between the pillars and the Turntable to prevent damage to the parts. Make sure that the center screw of the rotation is loose before erecting, and ensure that the column rotates smoothly when erecting. After standing tower, lock the post on the Turntable, and then tighten the rotation center screw. Note: If the equipment is transported long distances, or if it is sent overseas, the column and base are packed and shipped separately.

- (2) Use a random tool to install and fix the column on the Turntable (see the column installation diagram below for details).

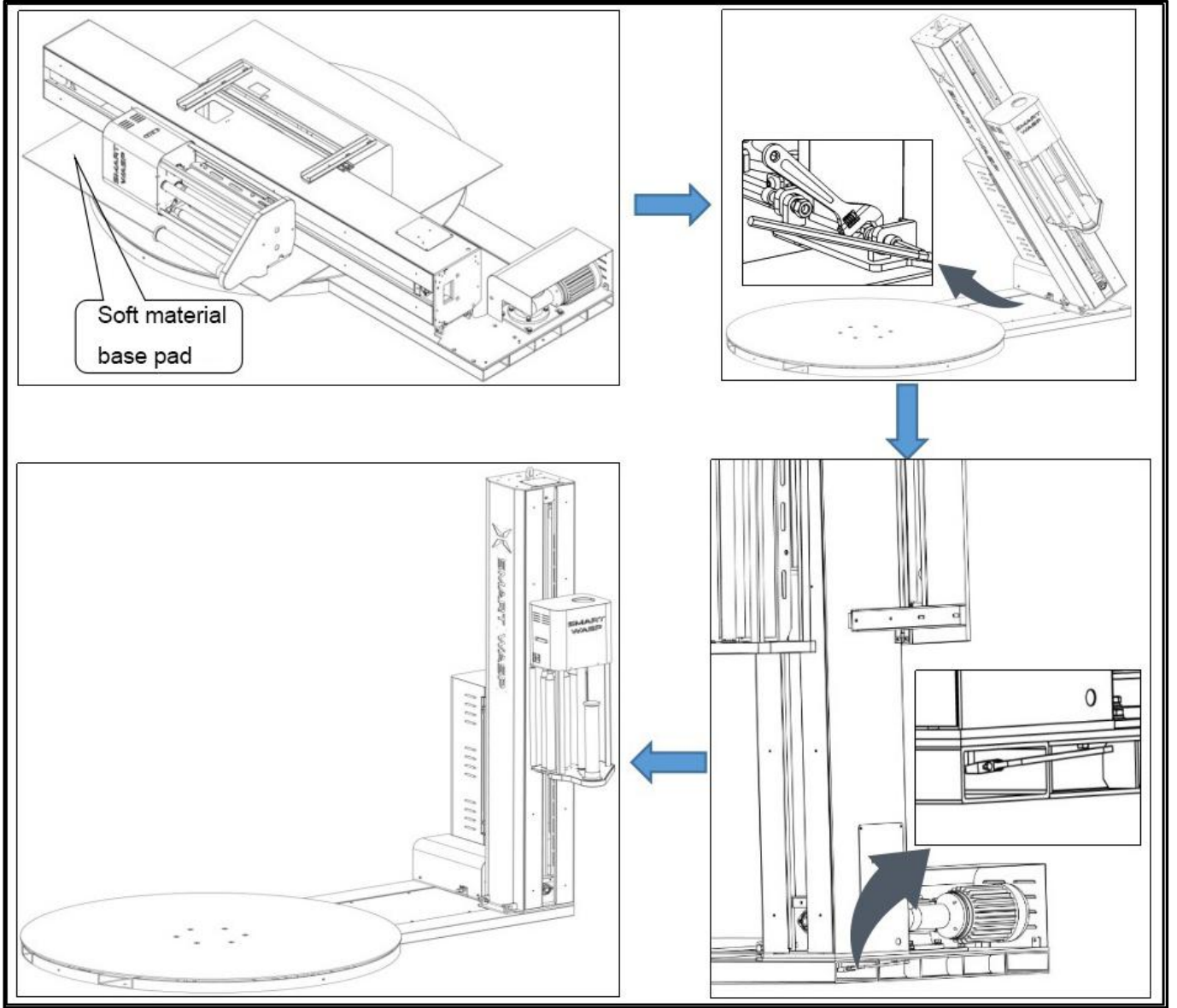

Figure 4.5.2.1

(3) Connect the Turntable motor and the sensor quick-connect aviation plug, and the connection is as shown in the figure below.



Figure 4.5.2.2

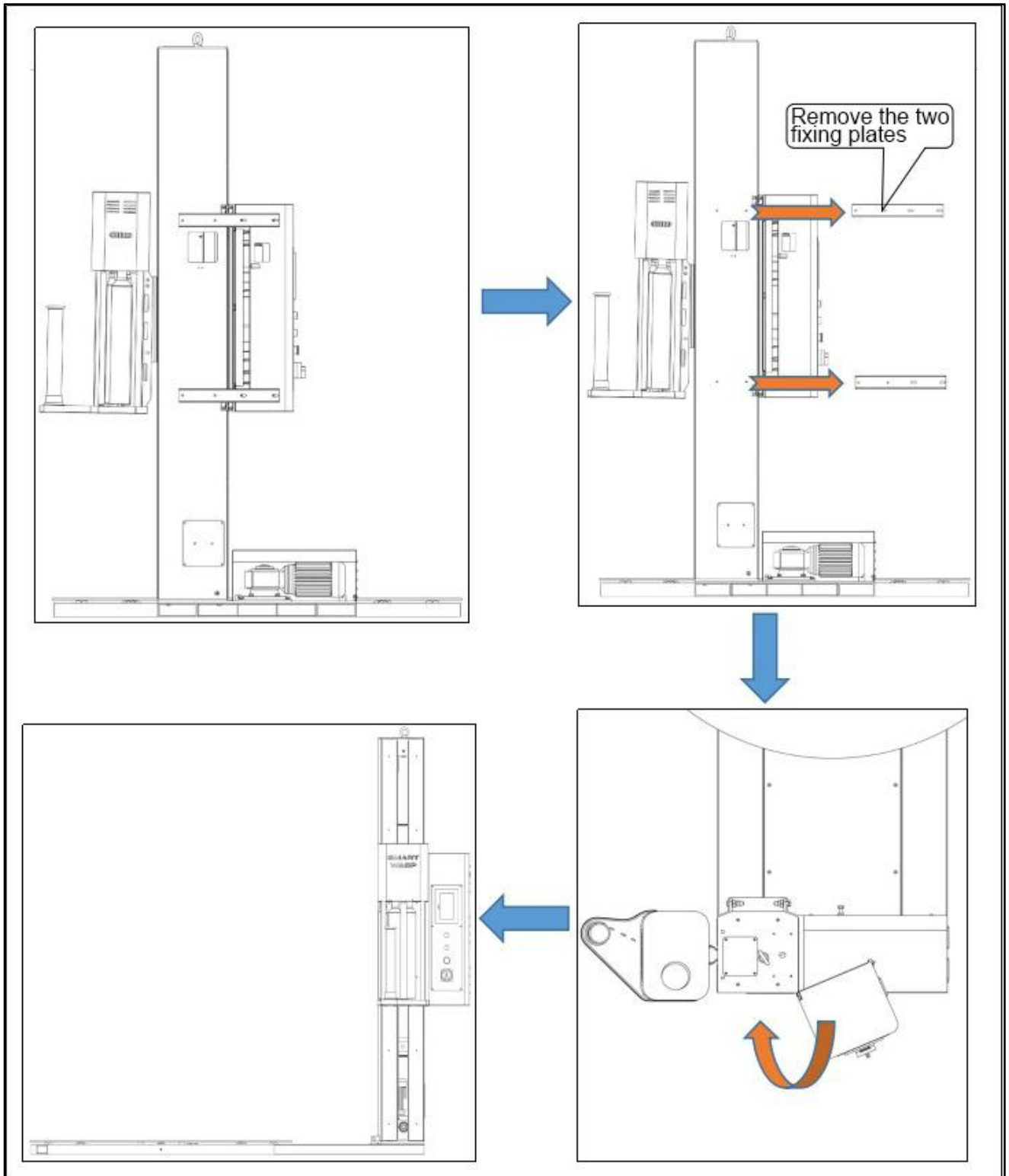

Figure 4.5.3.1

4.5.3 Electric control box installation

- (1) Use a suitable tool to remove the fixing plate used to fix the electric control box

during transportation, and place it properly for future transportation and fixing.

(2) Slowly rotate the electrical control box in the direction of the arrow (Figure 4.5.3.1) until one side fits the post.

(3) Open the door of the electric control box, and fasten the electric control box and the post with screws. (Figure 4.5.3.2)

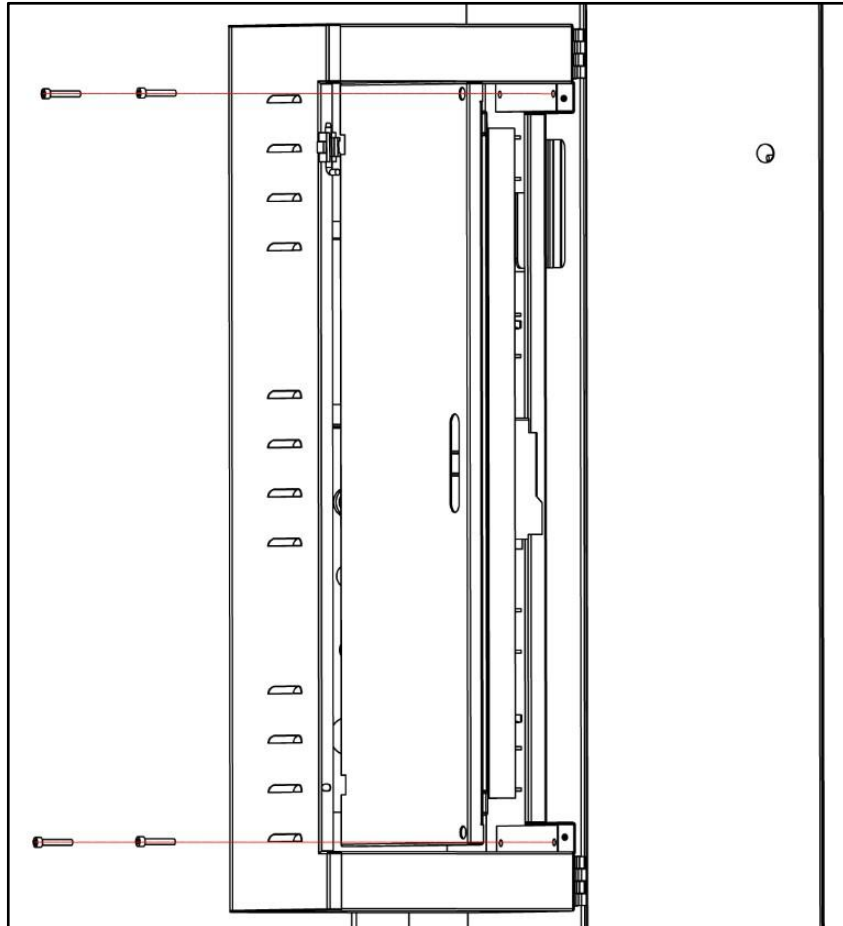

4.5.4 Film carriage installation

(1) Turn on the power and manually reset the Film carriage to the lower limit. Turn the main power switch counterclockwise to turn off the machine.

(2) Unscrew the screw used to fix the film exit lever to reset the film exit lever. As shown in Figure 4.5.4.1.



图 4.5.4.1

5 Instructions

5.1 safety instructions

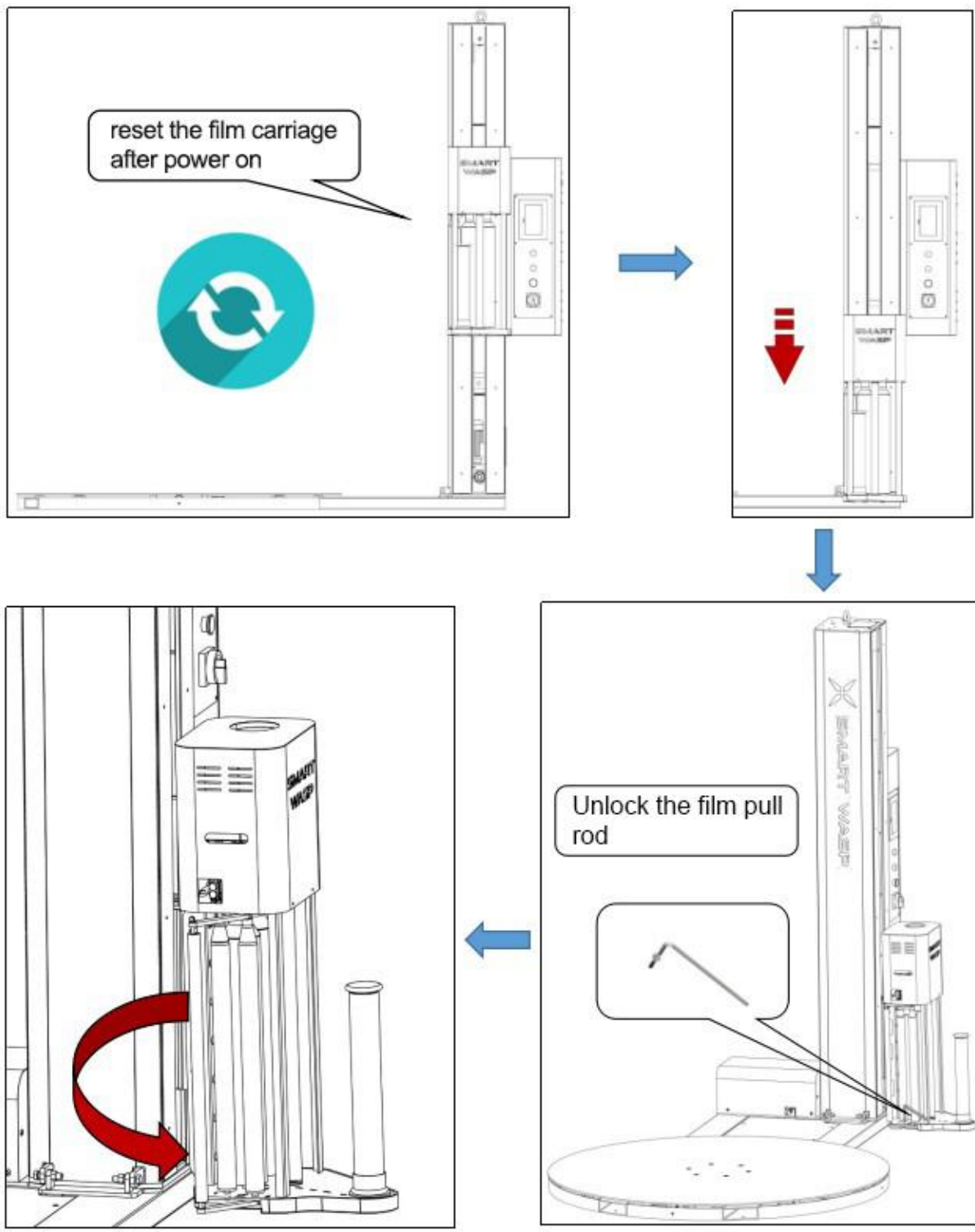

Warning

Strictly observe the operating safety regulations (refer to Section 2) and the instructions given in this chapter.

5.2 Operator tasks

1. Turn on the machine. See section 5.3.
2. Install the replacement film. See section 5.4.
3. Place a pallet on the Turntable. See section 5.5.
4. Fix the trailing end of the wrapping film to the cargo. See section 5.6.
5. Select a packing mode (see Section 5.13) or continue the current packing mode.
6. See Section 5.7 to start the packaging procedure.
7. The machine will complete a completed packaging cycle. When this cycle is complete, the pallet will stop at the home position.
8. Remove the pallet from the turntable.
9. Switch off the machine (see section 5.8).



Note: The above tasks for the operator are performed in accordance with standard work procedures.

See the following sections:

5.3 Turn on the machine

1. Turn the main switch clockwise (A) 

The power indicator (C) will light up.

2. If necessary, release the emergency stop button by (B) Turn the button clockwise.

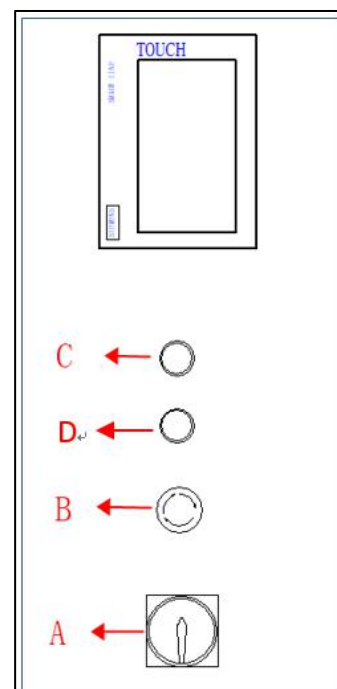

5.4 Installation and replacement of stretch film

**Note**

Use only roll types that meet the specifications given in Section 3.5.1.

1. First, ensure that the wrapping film is replaced while the machine is safely stopped.
2. Lift the used wrapping film core up from the roll holder and take it out.
3. Replace the film with a new standard-compliant wrapping film and place it on the film roll holder.
4. Follow the instruction of the arrow on the film carriage to convey the wound film through the guide roller.



Note: *Most types of wrapping film have an adhesive surface (A), which is called "adhesion." Since the inner side of the pallet must be wrapped with an adhesive material, make sure that the clings do not face the machine. If the film roll is the adhesive side that was originally wound on the inside, the wrapping film is worn as shown on the right*

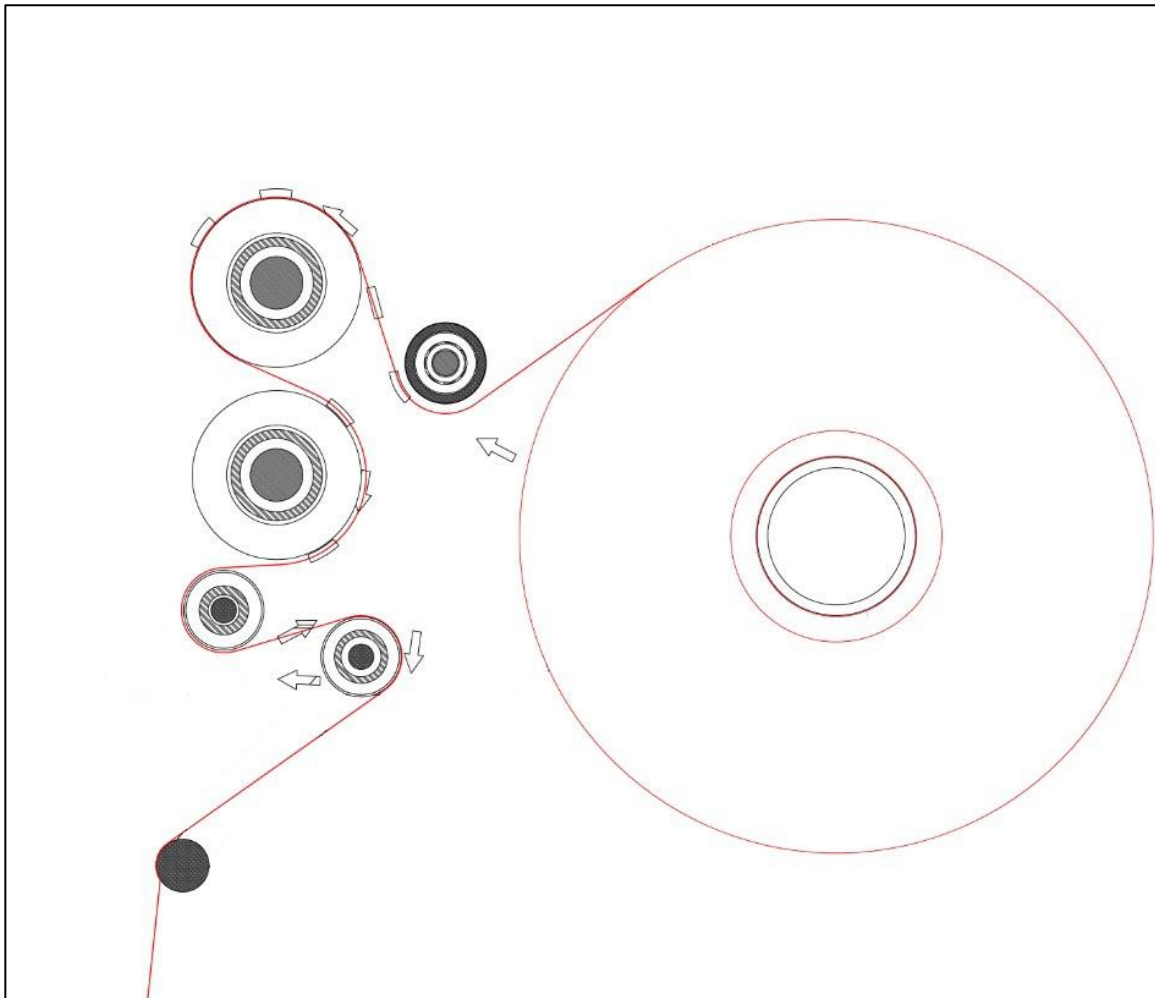

5. Feed the wrapping film into the turntable.
6. Tie the ends of the wrapping film to a pallet and the machine is now ready for packaging.

5.5 loading pallet instructions

The operation of the standard wrapping machine can be completed by an operator. The basic flow is shown in the figure below.

1. First make sure that there are no people or obstacles within 1 meter around the machine;
2. The goods are transferred to a standard wrapping machine by a forklift and placed as far as possible in the center of the turntable.

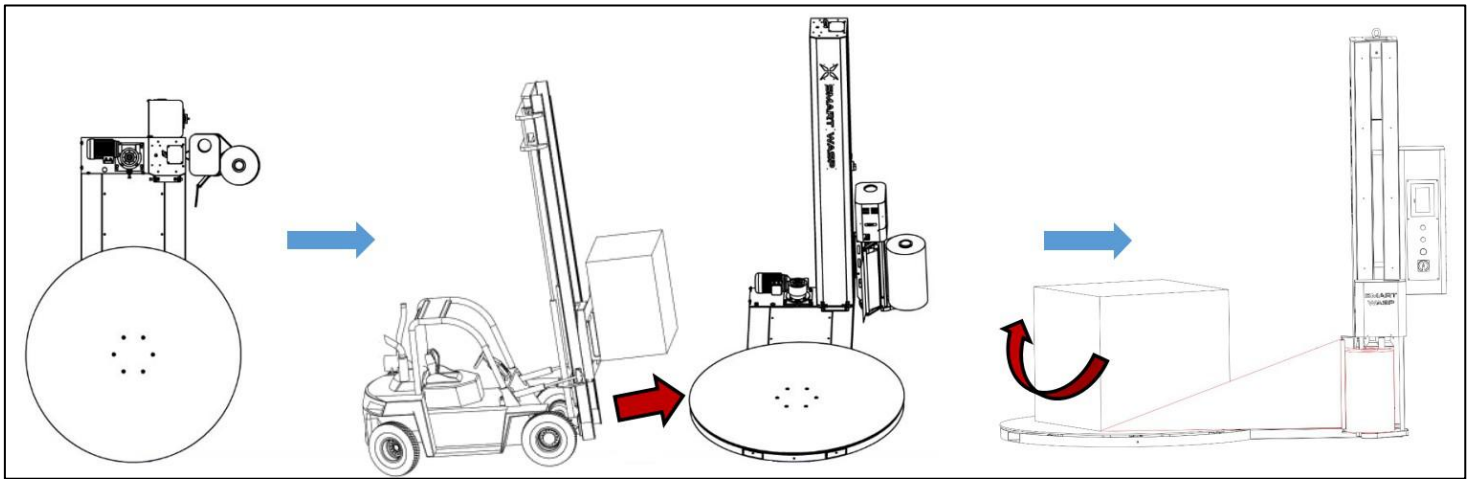

5.6 Stretch film installation operation

After the goods are placed, the first working packaging film needs to be manually hung on the broken film. The operation process is shown in the figure below.

1. After the film roll is placed, manually stretch the film to a sufficient length;
2. Expand the film with sufficient tackiness;
3. Pass the film through the film as indicated by the arrow on the film carriage
4. Pull the film by hand to attach it to the cargo, and squeeze it by hand so that it does not fall off when turning.

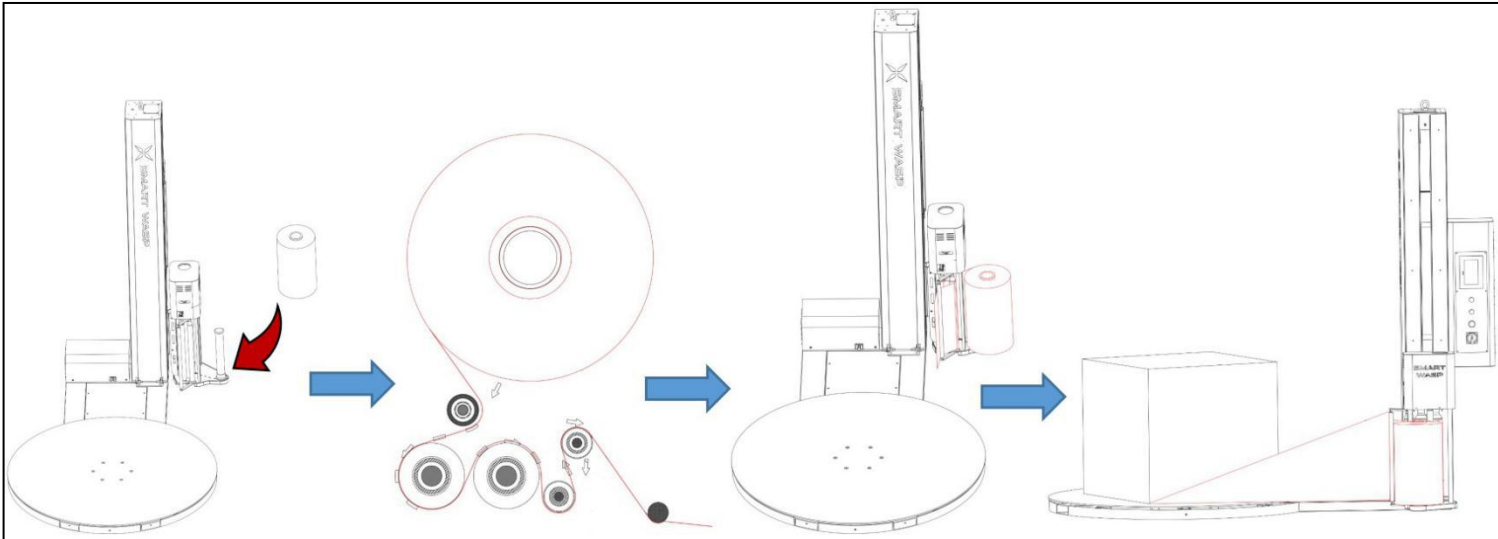

5.7 Turn on device

1. Check for error messages. See section 7.2.
2. Press one of the start buttons:

- Start button on the main control panel
- Start button on touch screen

After the start operation is completed, the turntable starts to rotate, and the pallet is wound around the film. At the end of the wrapping cycle, the turntable stops at the origin position.



Note

The machine can be paused during the wrapping process.

5.8 Turn off the device

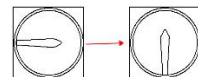

Turn off the machine if not used for a long time: Turn the main switch counterclockwise.





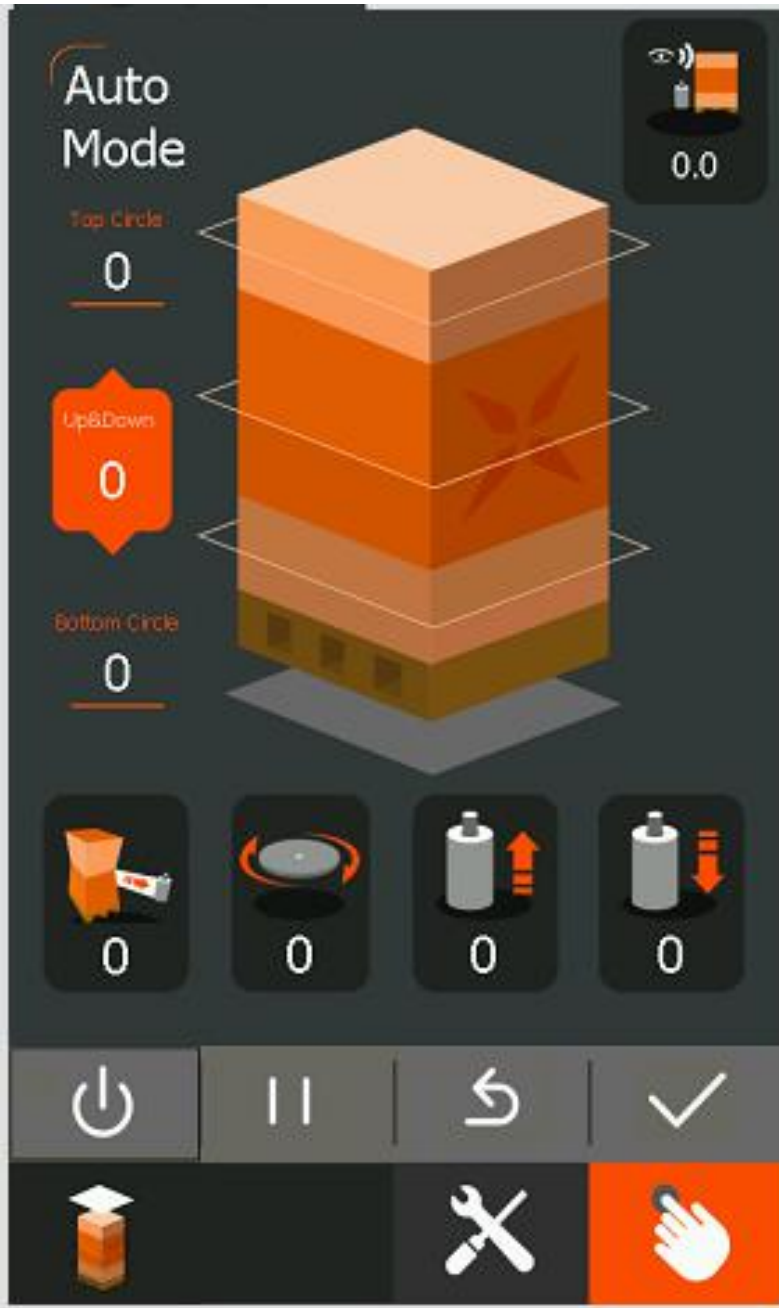











5.9 Touch screen homepage

1. Click anywhere on the start up page to enter the touch screen automatic operation screen.



Number	Name	Icon	Description
A	Wrapping mode setting		Number of turns around the film (reference setting value: 2)
			The number of turns around the bottom of the film (reference setting value: 2)

			Number of wrapping up and down (reference setting value: 1)
			Time to continue rising after detecting the height of the cargo (reference setting value: 2.5)
B	Speed setting		wrapping force: The tightness of the wrapping film. When the wrapping force increases, the Turntable speed increases and the film output speed decreases accordingly (setting range 0-100).
			Turntable speed: Turntable rotation speed (Setting range 0-100)
			Film up Speed: Film up Speed
			Film down speed: Film down speed of the Film carriage
C	Basic operation buttons		Start: The device automatically runs the start button
			Pause: Pause the current motion of the device. Press again to resume the pause
			Reset: Move the device to the origin position, the device can only be started when it is at the origin position
			Alarm Clear: Clear the currently triggered alarm signal

D	Manual		Independent control of different locations of the device.
E	Set up		The administrator performs related settings on the device
F	Top sheet		Click to select normal wrapping mode and cover film mode, the button turns green during cover film mode
G	Overlay mode		When the button is green, the operation mode is the top film mode

5.10 Pause packaging cycle (stop normally)

The machine can be temporarily stopped during the packaging cycle:

1. Press the touch screen pause key. The machine will gradually slow down and stop.
2. Resume packaging by pressing the pause button again.

Note

The machine will continue to run where it left off and complete the packaging process.



5.11 Automatic operation stop (emergency stop)

In case of emergency:

1. Press the emergency stop button (B).
2. The machine will stop immediately and the packing process will be aborted.

Note

After an emergency stop, the packaging cycle cannot be resumed.

5.12 Return to origin



When the device is not at the origin:

1. Press the reset button 
2. The machine will automatically reset to the origin position



5.13 Manual operation

You can select the manual operation mode on the screen:

Press  key, Go to the manual page.

1. Press the Turntable (A). The Turntable starts to rotate. Press the Turntable again. Stop rotation.
2. Press up (B) to start raising the Film carriage, press again or touch The film carriage stops rising when it hits the upper limit.
3. Press down (C) to start Film down the Film carriage, and then press it again or touch the lower limit The film carriage stops falling.
4. Press D to return to the automatic interface









Note

The speed of manual operation runs at the speed set on the automatic screen.





5.14 Administrator settings

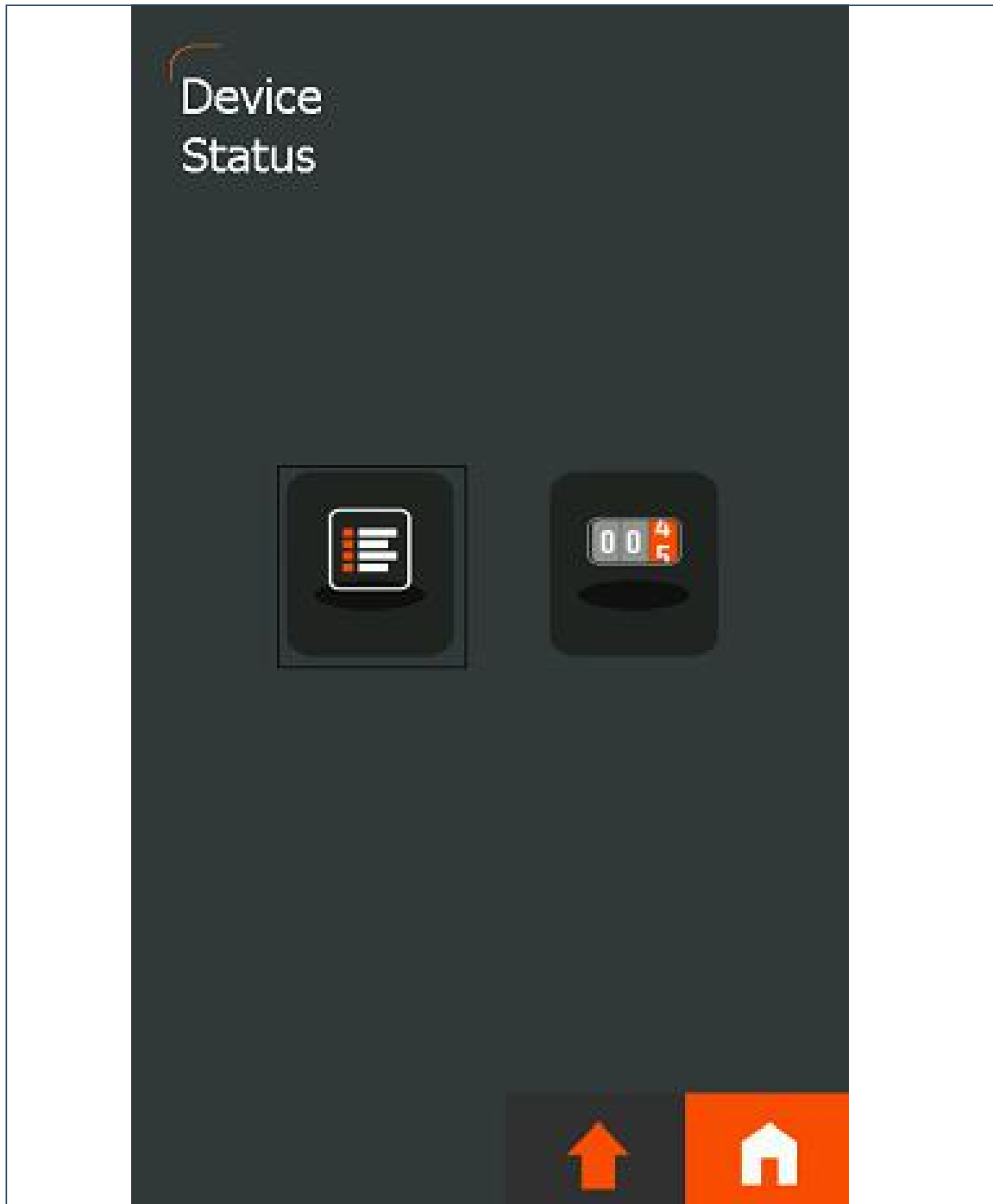

Number	Name	Icon	Description
A	equipment status		Jump to setting status page
B	parameter settings		Jump to the parameter setting page
C	Multiple choice interface		Jump to multi-select interface page
D	System time		Display the current system time
E	User password settings		Jump to user password setting interface
F	Homepage		Return to automatic screen





5.15 Equipment status

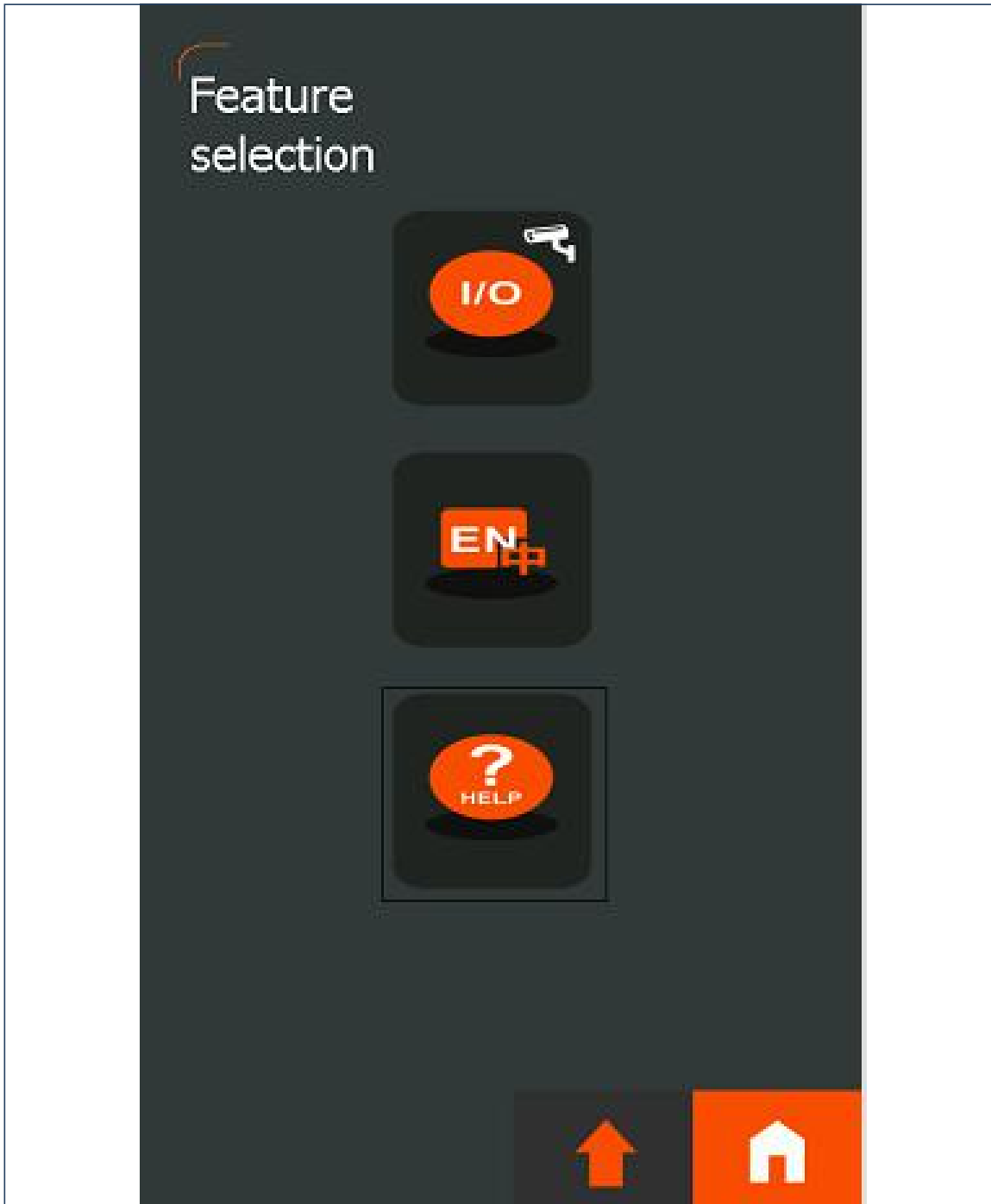

Number	Name	Icon	Description
A	Device Information		Jump to device information page
B	Production information		Jump to production information page
C	Administrator settings		Back to administrator settings page
D	Homepage		Return to automatic screen

5.16 Multiple choice interface

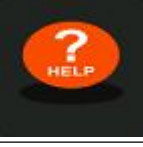
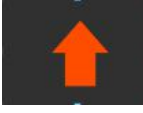

Number	Name	Icon	Description
A	I / O monitoring interface	 An orange circle with 'I/O' in white, a small white cursor arrow in the top right, and a dark shadow below.	Jump to I / O monitoring interface
B	language selection	 An orange square with 'EN' in white, a small white cursor arrow in the bottom right, and a dark shadow below.	Jump to language selection
C	I help page	 An orange circle with a white question mark and 'HELP' in white below it, and a dark shadow below.	Jump to the help page
D	Administrator settings	 An orange square with a white upward-pointing arrow and a dark shadow below.	Back to administrator settings page
E	Homepage	 An orange square with a white house icon and a dark shadow below.	Return to automatic screen

5.17 Parameter settings

System Parameter HELP



Parameter Modification

Slow Start Time	0.0	s
Slow Start Wrapping Force	0	%
Turntable Speed At Start	0	%
Descent Delay Time	0.0	s
Film Break Alarm Delay Time	0.0	s

Shield alarm of film break Shield alarm of carriage safety Parameter recovery

3/19/2020 8:42:39 AM ↑ 🏠

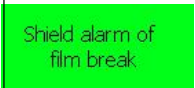
Number	Name	Description
A	Slow start time	Low speed running time of the Turntable at the start of automatic operation
B	Slow start Wrapping force	wrapping force of wrapping film during slow start
C	Turntable speed at start	During slow start, the Turntable runs fast
D	Descent delay time	Delay time for Film down the film carriage after wrapping to the top for the convenience of placing the film when running in the top-covering mode
E	Film break alarm delay time	When the device is in automatic operation, the film carriage that can trigger the film break alarm has stopped working for the duration

Number	Name	Icon	Description
A	Shield alarm of film break		The normal state is displayed in red, and the film break alarm can be shielded after one touch, and the shield state is green.
B	Shield alarm of carriage safety		The normal state is displayed in red, and the anti-pressure alarm can be masked after pressing once.

C	Parameter recovery	Parameter recovery	Press and hold, all parameters can be restored to factory values after 2 seconds
---	--------------------	--------------------	----------------------------------------------------------------------------------

5.18 Automatic operation

Device reset

After confirming the normal operation of each mechanism by manual operation, click the screen reset button to reset the device to the original position. At this time, the column LED light is blue.

Normal wrapping

After the reset is completed, confirm that the running mode is normal wrapping. The product can be transported to the Turntable and stabilized. After confirming that there is no error, press the start button and the device will start automatic operation. At this time, the LED light turns green. After the automatic wrapping is completed, The Turntable stops automatically, and the LED returns to blue at this time, and the device is completed to wrap.

Top sheet mode

After the reset is completed, confirm that the operation mode is the top mode. The product can be transported to the Turntable and stabilized. After confirming that there is no error, press the start button and the device will start automatic operation. At this time, the LED light will turn green and wait for the top to automatically wrap. After completing the top circle, the film carriage will descend for a certain period of time (that is, the delay time of the overriding mode in the parameter settings). At this time, the device is in a pause state, and the touchscreen will prompt the placement of the overlay film, as shown in the figure.





After the top film has been placed manually, click the Prevent Done button, which is The device will  start again and automatically complete the remaining actions until the wrapping is finished.

5.19 Alarm description

Film break alarm

When the device is in automatic operation, the film carriage motor should also be in continuous operation so that the device can exit the film normally. If the device is in automatic operation, but the film carriage motor has not been in the running state for a continuous period of time (that is, the film break alarm delay in the parameter settings), the film break alarm will be triggered at this time. As shown



At this time, the operator needs to confirm whether the wrapping film is exhausted or detached. After confirmation click  Clear the alarm signal. After the alarm is cleared, you can click  to reset it. Or click  keep wrapping.

Anti-pressure alarm

In manual operation, when a certain pressure is received at the bottom when the Film carriage is lowered, an anti-pressure alarm will be triggered, as shown in the figure,



At this time, the film carriage will immediately rise for 2 seconds, and then the device is paused. You need to click  to clear the alarm signal. At this time, the manual signal is cleared and the device is in a stopped state.

In automatic operation, when a certain pressure is received at the bottom when the film carriage is lowered, a pressure-proof alarm will be triggered. At this time, the film carriage will immediately rise for 2 seconds, and then the device is paused. Click  to clear the alarm signal. Operation mode, a yellow waiting bar will be displayed on the start button, as shown in the figure



At this point, you can choose to  reset it. Or click  to continue wrapping.

Emergency stop alarm

At any time, press the emergency stop button, the device will stop all actions, be in a stopped state, and trigger an emergency stop alarm, as shown in the figure.



Emergency Stop

When you can confirm that you can start again, you need to turn the emergency stop button to make the button pop up, and click  to clear the alarm signal.

6 Care and maintenance instructions

6.1 Safety instructions



Warning

Strictly follow the safety instructions that apply during maintenance (see section 2.2.10) and the instructions given in this chapter.

6.2 Preparation for maintenance

1. Before starting any maintenance work (or cleaning):
2. Turn the main switch to the "OFF" position.
3. Unplug the power plug from the power outlet.
4. Wait for at least two minutes.

6.3 End of maintenance

1. Immediately after the maintenance work is completed, reactivate or enable (temporarily) disabled safety features.
2. Before cleaning the machine for production, be sure to check that the safety features function properly.

6.4 Maintenance schedule

Maintenance tasks	√	Maintenance interval			
	Chapter	Daily check	Monthly check	Annual inspection	Check every 3 months
Check the function of safety facilities	6.5	√			
Cleaning machine	6.6		√		

Cleaning the rollers on the film carriage	6.7		√		
Add lubricating oil to seated bearings	6.10				√
Lubricated Turntable transmission chain	6.11				√
Check the chain tension of the drive chain in the column	6.12				√
Checking the travel wheels of the Turntable	6.13			√	

6.5 Check the function of safety facilities



Warning

Be careful of the machines that need to be operated when checking safety facilities.

1. Check that all safety decals and instructions are legible
2. Inspect the power cord for damage.
3. Check the following facilities:
 - Emergency stop button (see section 2.5.2);
 - Film carriage safety plate and foot protection switch.

6.6 Cleaning machine

1. Check that the system is safe, see section 6.2.
2. Clean the machine with a dry cloth or mild detergent.



Warning

Never use solvents, gasoline, etc. to clean the machine

6.7 Cleaning the rollers on the film carriage



Note
Some types of film leave a layer of sticky glue on the surface of the film carriage roller, which can cause the film to slide on the roller.

1. Check that the system is safe, see section 6.2.
2. Scrub the surface of the roller (A) with alcohol to restore the adhesion between the roller and the film.

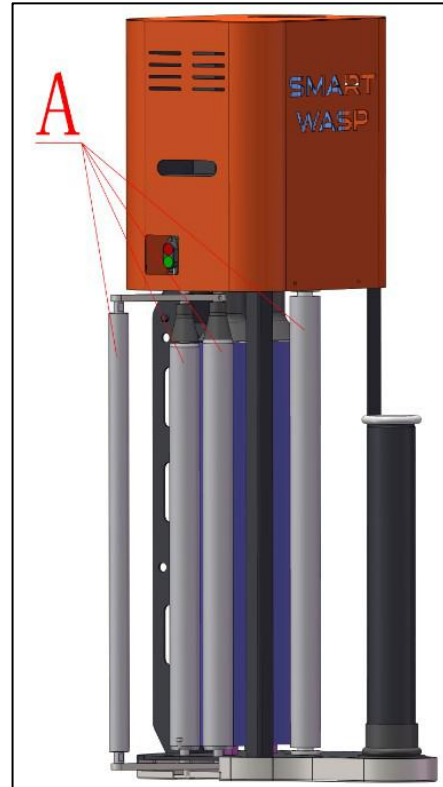

6.10 Add lubricating oil to seated bearings



Note
 Before leaving the factory, the bearing seat in the column has been lubricated. If it is used for a long time, it is still necessary to add lubricating oil.



1. Check the system for security, see section 6.2
2. Operate the machine to manually raise the diaphragm seat to facilitate adding lubricant to the seated bearing
3. Add lubricating oil to the oil inlet of the bearing block (A) of the lifting power frame

6.11 Check turntable chain tension and lubricate



Note
 Before leaving the factory, the Turntable drive chain has been lubricated, and it will still need to be added for a long time.

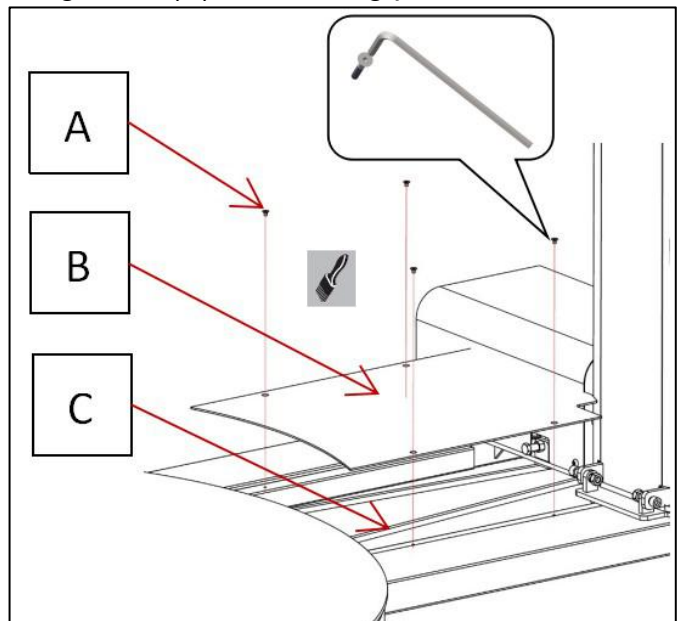

1. Check the system for security, see section 6.2.
2. Loosen the fasteners (A).
3. Remove the chain cover (B).
4. Check the tension of the transmission chain (C)
5. Lubricate the drive chain (C) with chain grease.
6. Attach the chain cover (B).

If the chain is loose, tension the chain as follows:

1. Loosen the four fasteners of the Turntable motor cover, and slightly loosen the fasteners (A) of the motor mounting plate.
2. Adjust the chain tension with the chain tension bolt (B).
3. Tighten the four fasteners (A).
4. Check the tension of the drive chain again.
5. After the adjustment is complete, proceed in the reverse order and reinstall the removed parts.

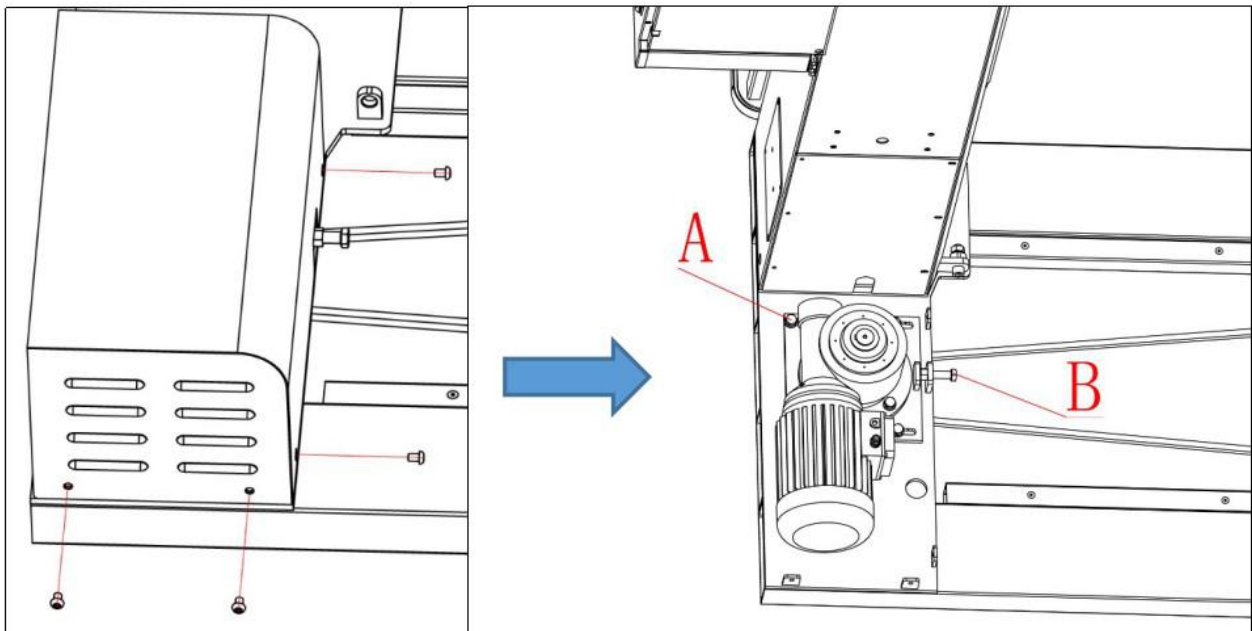

6.13 Checking the travel wheels of the Turntable

1. Check the system for security, see section 6.2
2. Loosen the six fasteners (A) on the turntable (B).

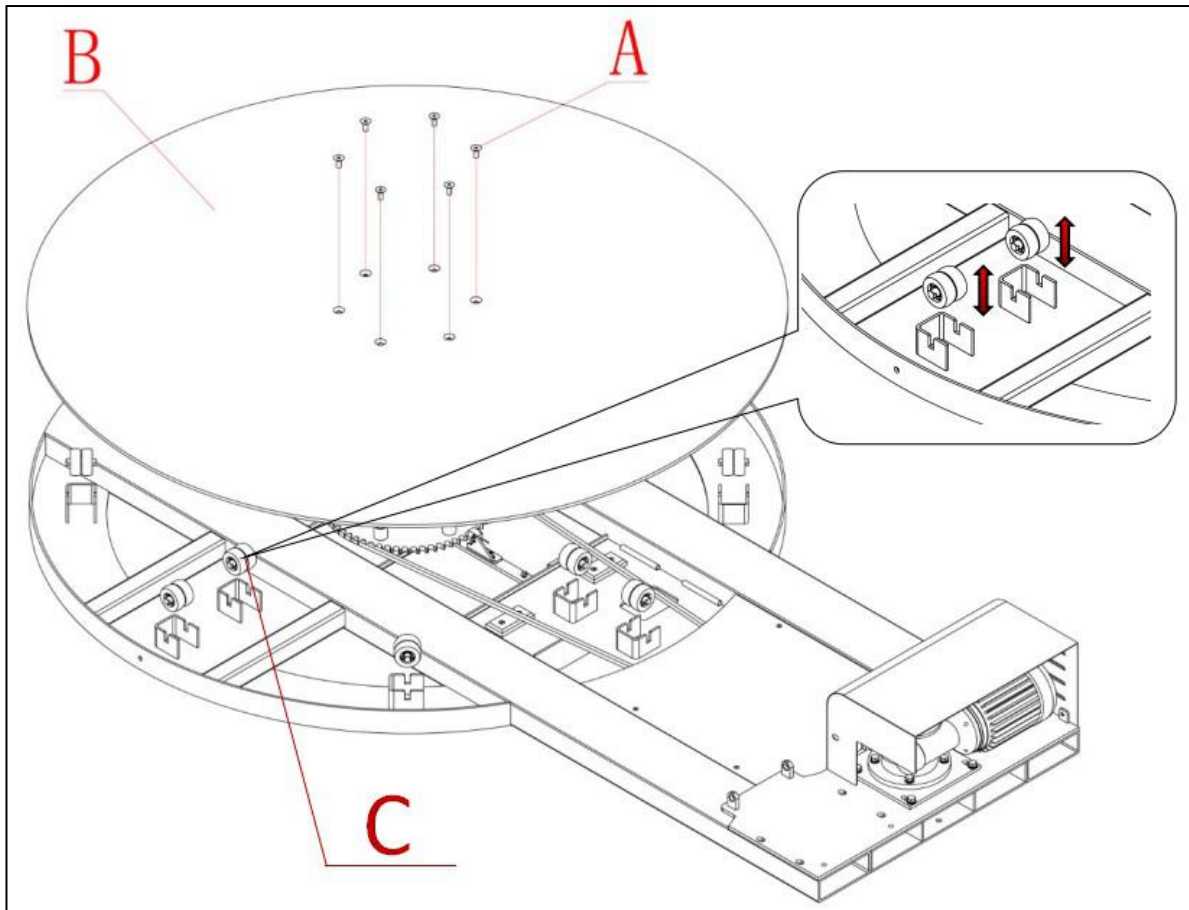

3. Remove the turntable (B).
4. Check the condition of the walking wheel (C).
5. If damaged, replace the wheel assembly.
6. After the inspection and repair are completed, proceed in the reverse order and reinstall the removed parts.



6.14 Check column chain tension and lubricate



Note

Before leaving the factory, the post drive chain has been  lubricated, and it will still need to be added  for a long time.

1. Check the system for safety, see section 6.2;
2. Refer to 6.11 to check the tension of the Turntable chain and lubricate, first **loosen the four fasteners of the Turntable motor cover;**
3. Then loosen the pillar lower cover fastener and remove the pillar lower cover, as shown in the figure below;
4. Manually raise the film carriage to the bottom of the column with sufficient

spanner space;

5. Check the tension of the column transmission chain;
6. If the chain is loose, use a wrench to tighten the tension bolts on the chain;
7. Lubricate the tower chain with chain grease;
8. First install the pillar lower cover, and then install the Turntable motor cover.
9. Reset Film carriage

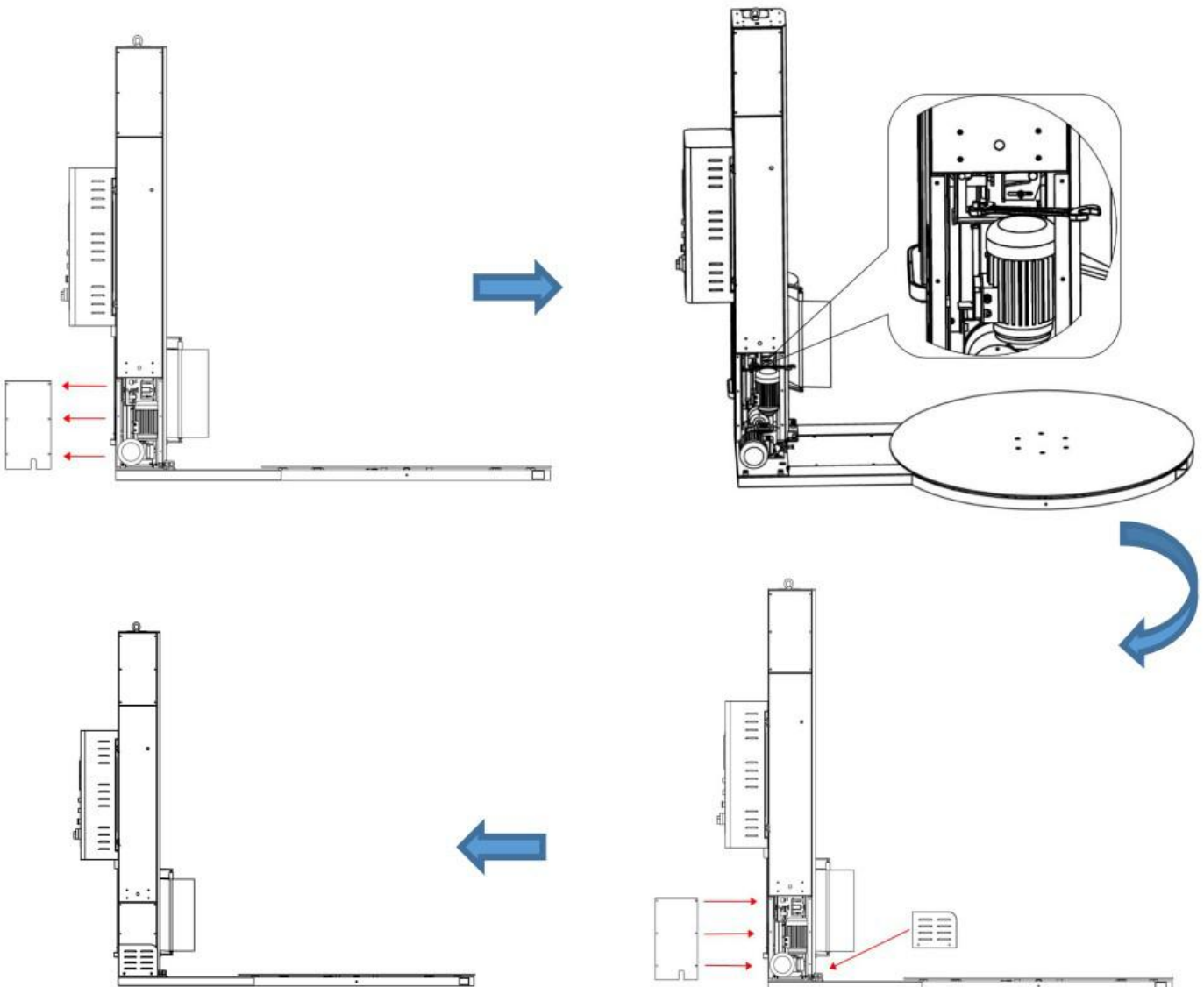

7 Troubleshooting instructions

7.1 Safety instructions



Warning

Strict compliance with safety regulations

For repairs and troubleshooting see 2.2.11

7.2 Troubleshooting

7.2.1 Inverter alarm message description

The following table shows the alarm messages, possible causes, and solutions to be taken on the operation panel of the inverter.

Serial number	malfunction	the reason	deal with
1	F1 Overcurrent	<ul style="list-style-type: none"> The motor power (P0307) is not the same as the inverter power (r0206). Motor wire short Ground Fault r0949 = 0: hardware report r0949 = 1: software report r0949 = 22: hardware report	Check the following: <ul style="list-style-type: none"> The motor power (P0307) must be the same as the inverter power (r0206). The cable length must not exceed the permitted limits. There must be no short circuit or ground fault in the motor cable and inside the motor. The motor parameters must match the actual motor used. The stator resistance value (P0350) must be correct. The motor must not be blocked or overloaded. Increase the ramp-up time (P1120) Reduce start-up lifting strength (P1312)
2	F2 Over voltage	<ul style="list-style-type: none"> Power supply voltage is too high Motor is in regeneration mode r0949 = 0: hardware	Check the following: <ul style="list-style-type: none"> The power supply voltage (P0210) must be within the range specified on the nameplate. The ramp-down time (P1121) must match the load inertia. The required braking power must be within the specified range.

		<p>report</p> <p>r0949 = 1 or 2:</p> <p>software report</p>	<ul style="list-style-type: none"> The Vdc controller must be enabled (P1240) and the parameter settings are correct. <p>Explanation:</p> <p>Excessive ramp down or motor driven by an active load may cause the motor to be in regenerative mode.</p> <p>The higher the inertia, the longer the ramp time is required; otherwise, a braking resistor needs to be connected.</p>
3	F3 Under voltage	<ul style="list-style-type: none"> electricity failure. The impact load exceeds the specified limit. <p>r0949 = 0: hardware report</p> <p>r0949 = 1 or 2: software report</p>	<p>Check the power supply voltage.</p>
4	F4 Inverter overheating	<ul style="list-style-type: none"> Inverter overload Insufficient ventilation Pulse frequency is too high Ambient temperature is too high Fan is not working 	<p>Check the following:</p> <ul style="list-style-type: none"> Is the load or load cycle too high? Motor power (P0307) must match inverter power (R0206). Pulse frequency must be set to the default value The ambient temperature is too high? The fan must rotate when the inverter is running
5	F4 Inverter overheating	<ul style="list-style-type: none"> Inverter overload Insufficient ventilation Pulse frequency is too high Ambient temperature is too high Fan is not working 	<p>Check the following:</p> <ul style="list-style-type: none"> Is the load or load cycle too high? The motor power (P0307) must match the inverter power (R0206). Pulse frequency must be set to the default value The ambient temperature is too high? The fan must rotate when the inverter is running

6	F5 Inverter I2t	<ul style="list-style-type: none"> The inverter is overloaded. Load cycle demand is too high. The motor power (P0307) exceeds the inverter power (r0206). 	<p>Check the following:</p> <ul style="list-style-type: none"> The duty cycle must be within the specified range. The motor power (P0307) must match the inverter power (R0206). <p>Note: The F5 fault can only be cleared when the inverter overload utilization (r0036) is lower than the inverter I2t alarm (P0294).</p>
7	F11 Motor overheating	<ul style="list-style-type: none"> Motor overload 	<p>Check the following:</p> <ul style="list-style-type: none"> Is the load or load step too high? Motor nominal overheating parameters (P0626-P0628) must be set correctly Motor temperature alarm threshold (P0604) must match
8	A501 Current limit	<ul style="list-style-type: none"> The motor power is inconsistent with the inverter power Motor lead is too long Ground Fault 	See F1.
		<ul style="list-style-type: none"> Small size motor (120 W) in FCC and light May cause higher current values when operating under load conditions 	V / f control mode for smaller motors
9	A502 Over-voltage limit	Over voltage limit reached. If Vdc control is disabled(P1240 = 0), this alarm may occur when the ramp is down.	If the alarm is always displayed, check the inverter input voltage.
10	A503 Under voltage limit	<ul style="list-style-type: none"> electricity failure. The power supply voltage and DC bus 	Check the power supply voltage.

		voltage (r0026) are below the specified limits.	
11	A504 Inverter overheating	The alarm threshold for the heat sink temperature of the inverter, the alarm threshold for the chip junction temperature, or the allowable change in the temperature at the junction of the chip has caused the pulse frequency Decrease and / or decrease the output frequency (depending on the parameter settings in P0290).	Explanation: r0037 [0]: radiator temperature r0037 [1]: Chip junction temperature (including heat sink) check The following: <ul style="list-style-type: none"> • Ambient temperature must be within specified limits • Load conditions and load steps must be appropriate • The fan must rotate when the inverter is running
12	A506 IGBT junction temperature rise alarm	Overload alarm. The difference between the junction temperature of the heat sink and the IGBT exceeds the alarm limit.	Check whether the load step and impact load are within the specified limits.
13	A511 Motor overheating I2t	<ul style="list-style-type: none"> • Motor overload. • The duty cycle or load step is too high. 	Regardless of the form of temperature determination, the following should be checked: <ul style="list-style-type: none"> • P0604 Motor temperature alarm threshold • P0625 Motor ambient temperature • Check that the nameplate data is correct. If it is not correct, perform quick commissioning. By performing motor data identification • (P1900 = 2), accurate equivalent circuit data can be obtained.

			<ul style="list-style-type: none"> • Check whether the motor weight (P0344) is reasonable. If necessary, replace the motor. • If the motor is not a Siemens standard motor, change the standard overheating temperature through P0626, P0627, and P0628.
14	A922 Inverter without load	The inverter is unloaded. Therefore, under normal load conditions, some functions may not be implemented.	Check whether the motor is connected to the inverter.

7.2.3 Common mechanical faults and troubleshooting

Serial number	Fault description	possible reason	Solution
1	Turntable does not rotate after start up	1. Emergency stop button was pressed 2. The chain comes off or breaks	1. Turn the "emergency stop button" on the operation panel to eliminate the "emergency stop alarm", and the red light at the top will disappear. 2. Open the Turntable and bottom door, change the chain, and adjust the chain tension
2	Abnormal sound when the turntable rotates Or difficult to start	1. Equipment is placed on uneven ground 2. Broken bottom roller 3. Lack of lubricant on the chain 4. Overweight	1. Place the device on a flat surface and keep it clean 2. Reinstall the bottom roller or replace 3. See "Maintenance and Maintenance" for details 4. Check whether the bottom roller is loose or damaged, and check the weight of the cargo (the cargo should be selected within the rated load range. For detailed range values, refer to the technical parameter table)
3	turntable does not reset Or reset inaccurate	1. Loose or damaged sensor at the bottom of the turntable 2. Line damage	1 Adjust the distance between the sensor and the sensor sheet or replace the sensor. 2 Check the wiring and replace the faulty wiring
4	Membrane abnormal sound	1. Lack of lubricant on the chain 2. Foreign body in the chain	1. See 6 Care and Maintenance Instructions for details 2. Remove foreign body
5	Unable to pack on top of the cargo	1. Sensor detects position deviation 2. Damaged sensor 3. Overshoot time is too short	1. Adjust sensor to detect distance or position 2. Replace the sensor 3. Adjusted the top room (see 5 operating instructions for details)

6	Film carriage abnormal film	<ol style="list-style-type: none"> 1. Sensor detects position deviation 2. Damaged sensor 3. The chain comes off, breaks, or has foreign objects 	<ol style="list-style-type: none"> 1. Adjust sensor to detect distance or position 2. Replace the sensor 3. Clean up foreign objects or rein stall the chain
7	Film wrapping is too tight / too loose / pulled off / broken	<ol style="list-style-type: none"> 1. The film-pulling roller is stuck with debris 2. Large difference between film release speed and Turntable speed 	<ol style="list-style-type: none"> 1. Use alcohol to clean the surface of the pull-film roller (do not use sharp tools such as a knife to clean) 2. Adjust the motor speed (see 5 operating instructions for details)
8	Film carriage back film	<ol style="list-style-type: none"> 1. Film carriage power roller reverse 2. Untightened film during operation 	<ol style="list-style-type: none"> 1. Check the line, if necessary, change U2 / V2 2. Tighten film to prevent film rolling when applying film
9	Machine starts without action	<ol style="list-style-type: none"> 1. Power is not plugged in 2. Emergency stop button was pressed 3. Inverter alarm 	<ol style="list-style-type: none"> 1. Insert the power plug 2. Rotate the emergency stop button to eliminate the emergency stop 3. Press the "OK" button of the inverter

8 Appendix

8.1 Electrical schematic

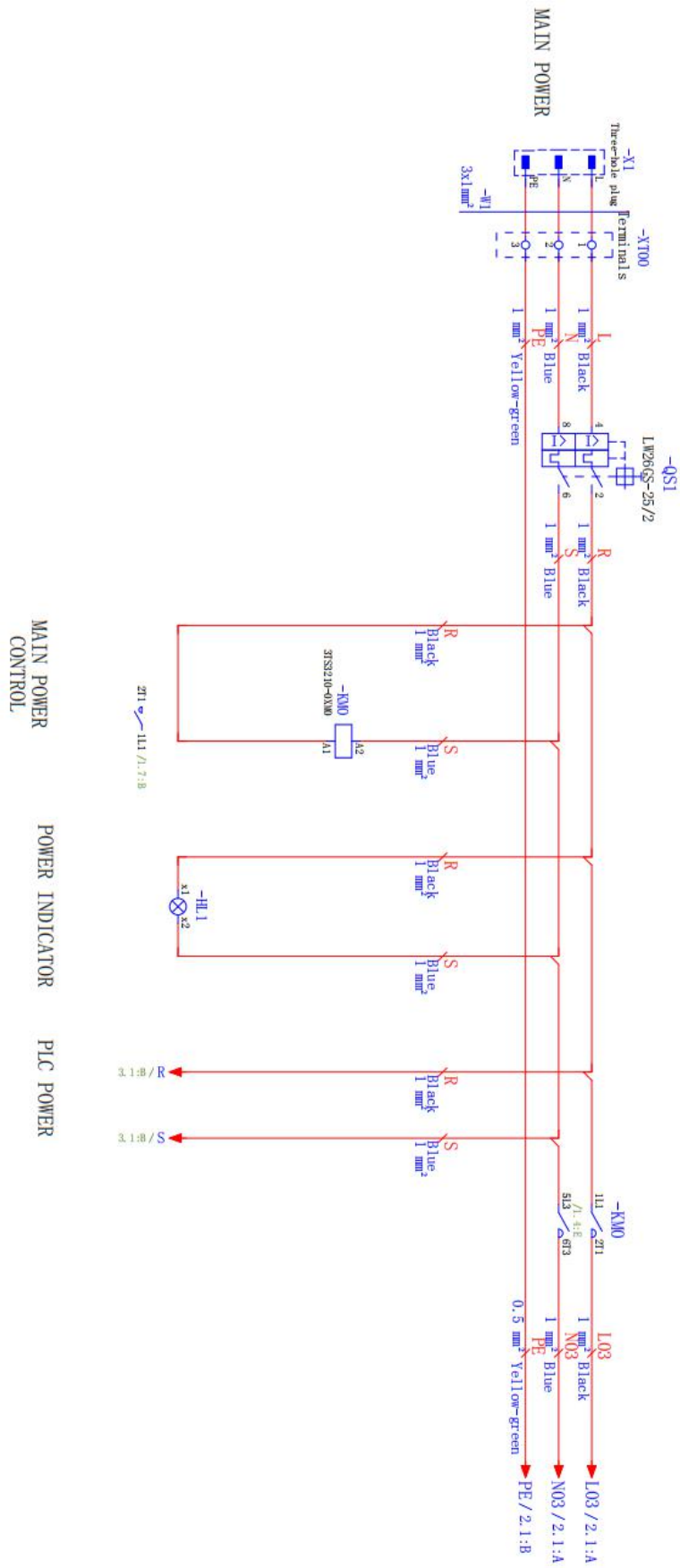

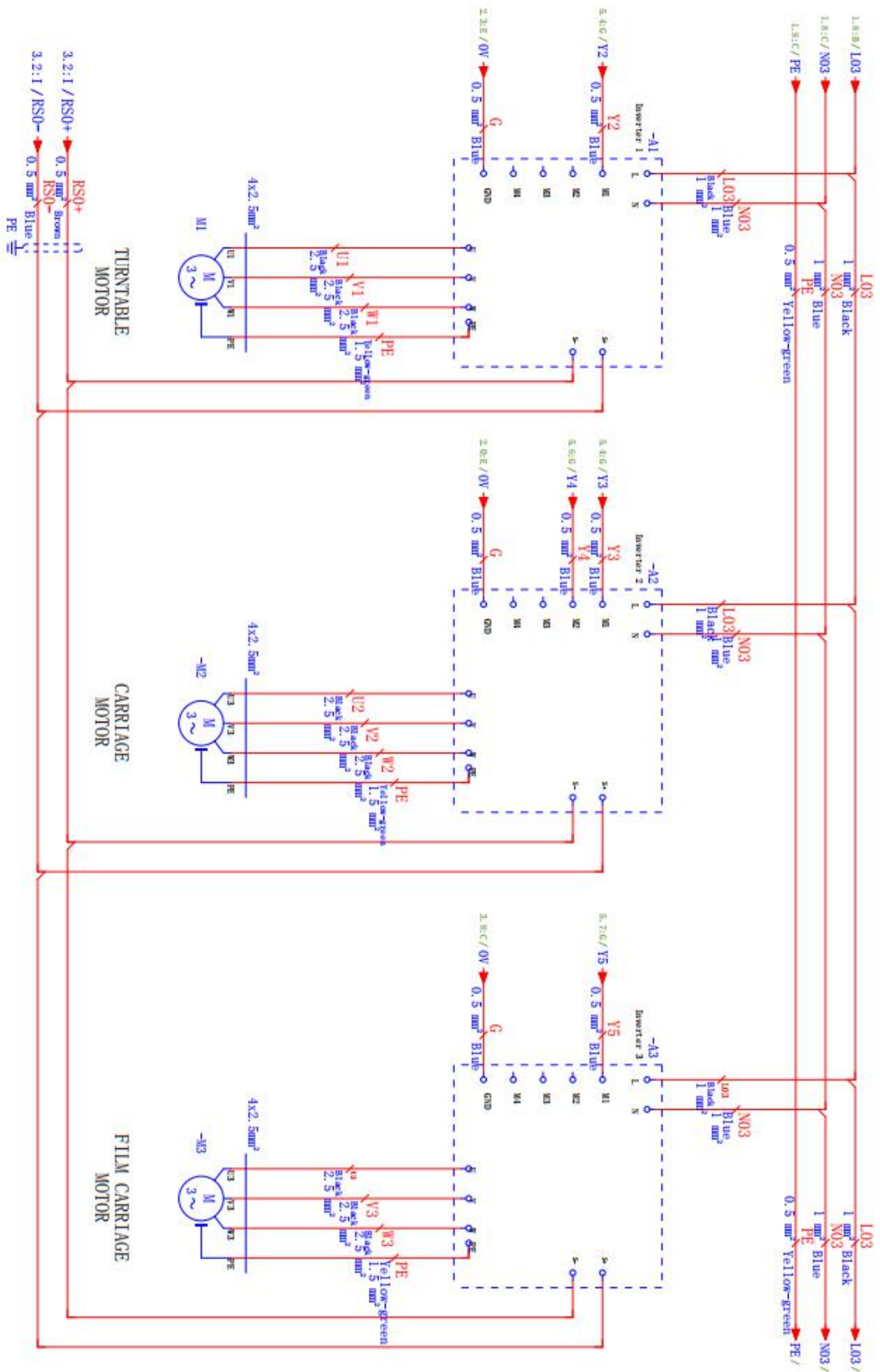

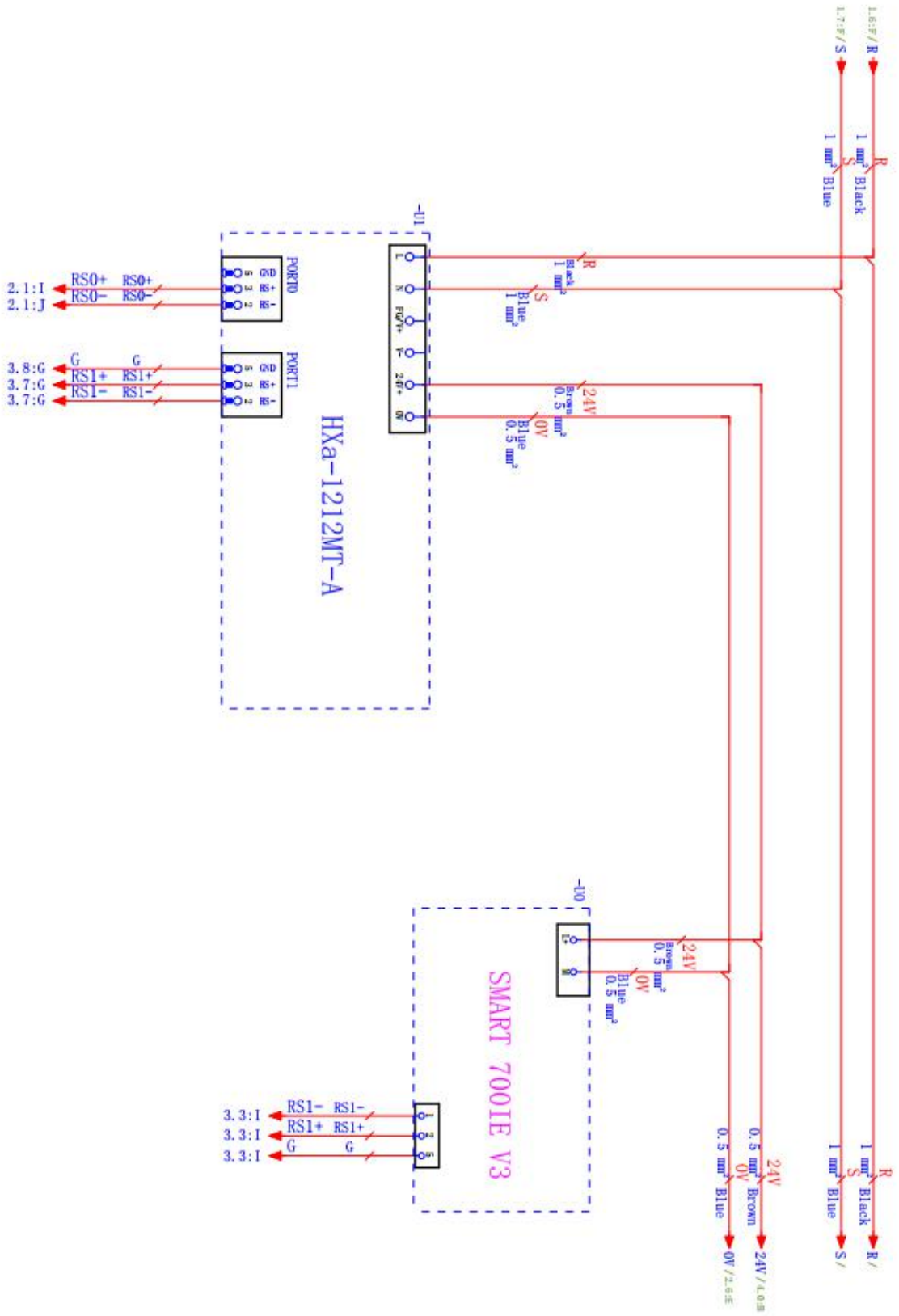

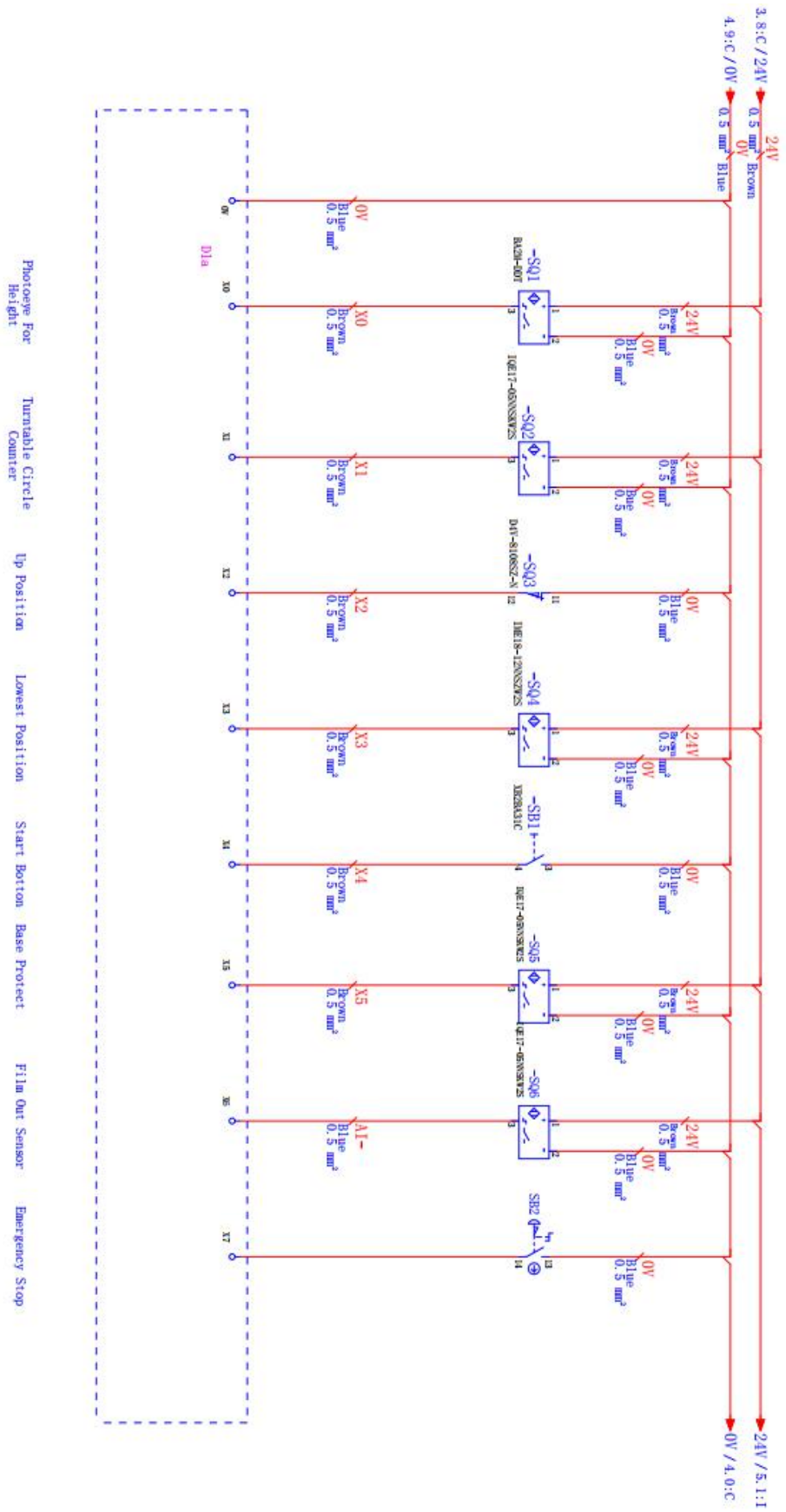

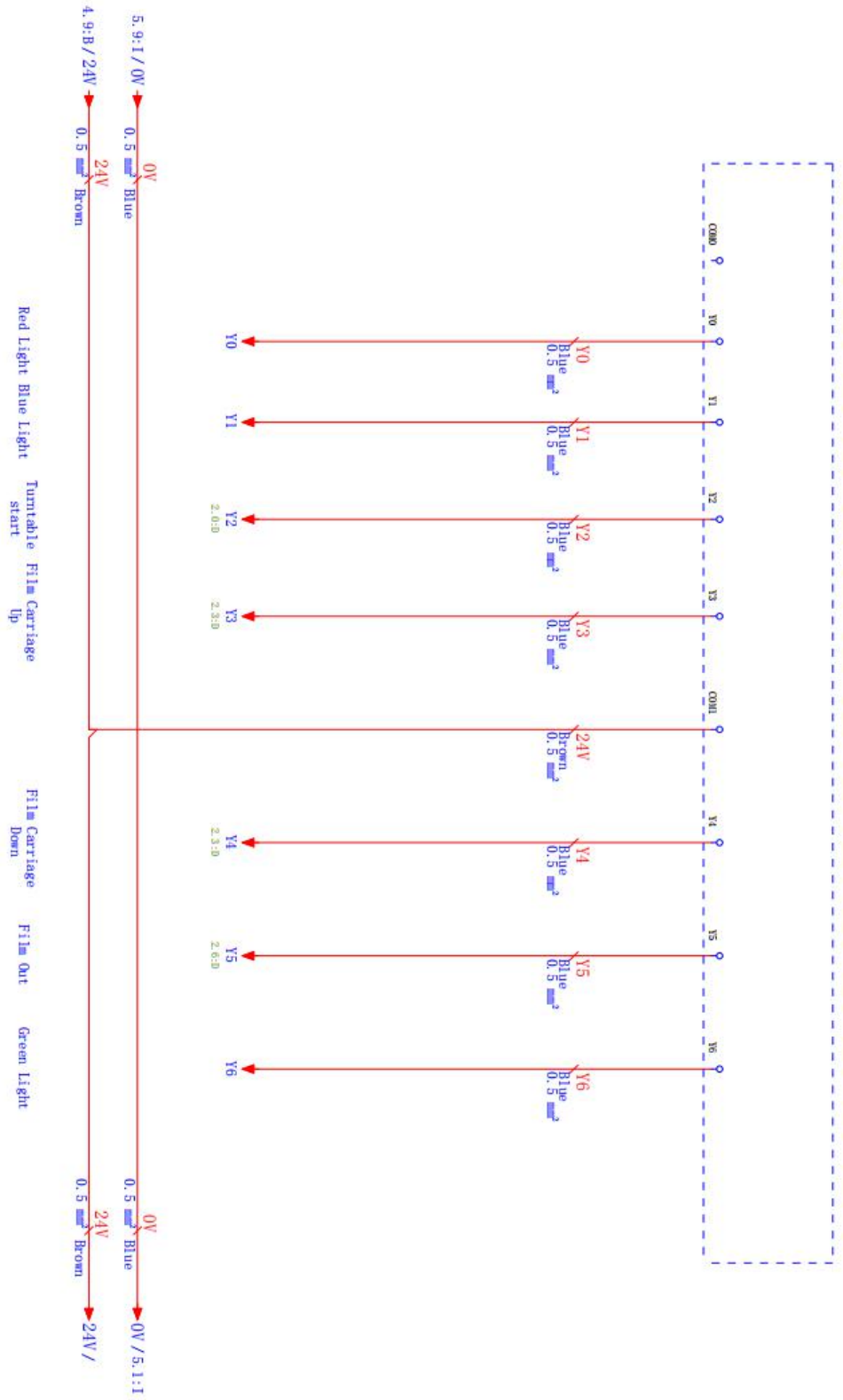

8.2 Exploded view and detailed list

8.2.1 Turntable exploded view and detailed list

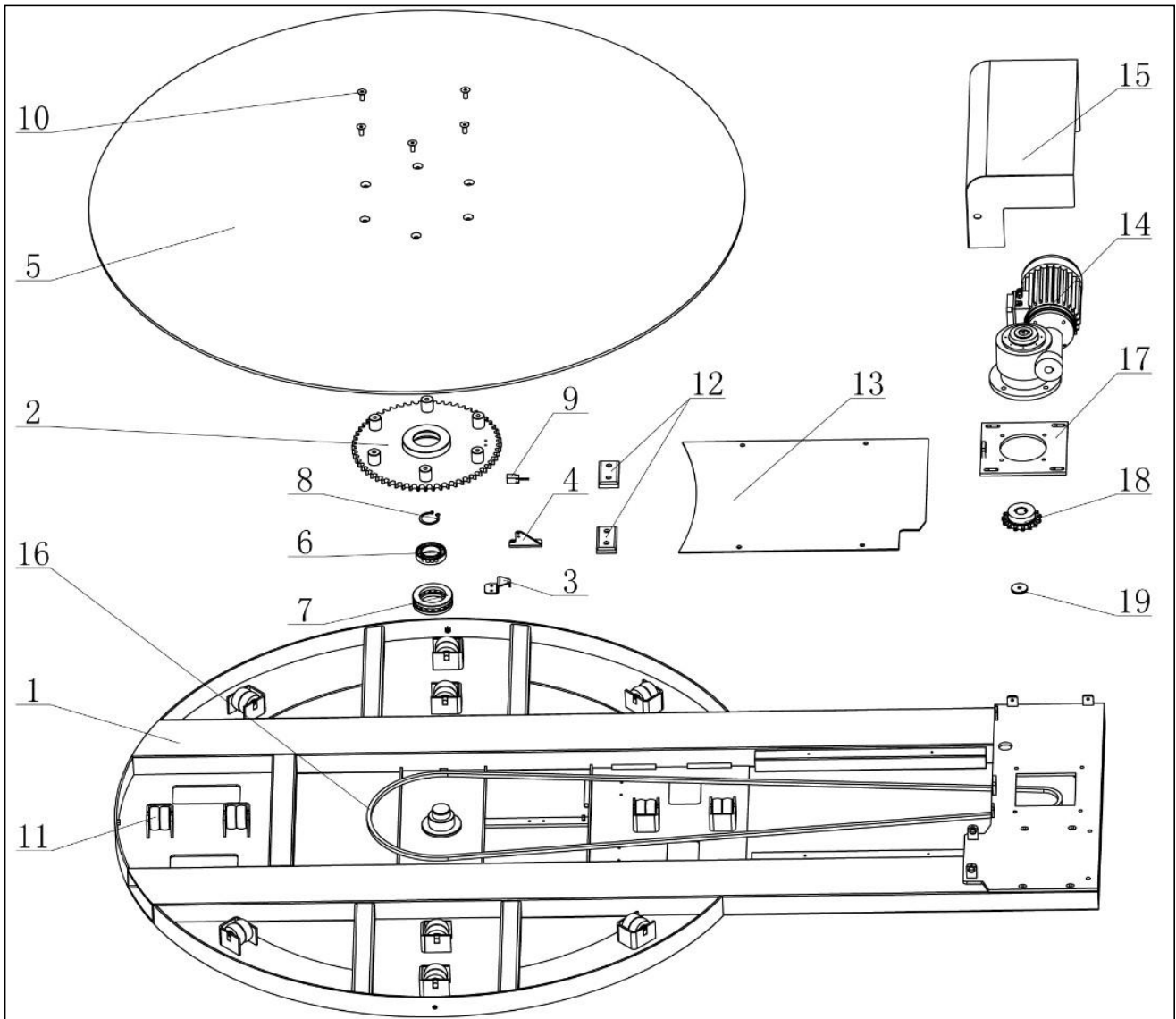

Serial number	Workpiece number	Artifact name	Quantity
1	9XXDA000330	1650 Simple Round Turntable Welding Parts	1
2	9XXDA000014	Turntable sprocket weldment	1
3	9XXDA000006	Bottom sensing block	1
4	9XXDA000051	Proximity switch mounting plate	1
5	9XXDA000332	1650 Turntable	1
6	JZCSG000015	Deep groove ball bearing 6009	1
7	JZCTL000001	Thrust ball bearings 51213	1
8	JDQZY000001	Shaft retaining ring $\Phi 45 \times 1.5$	1
9	DKGJJ000001	Proximity switch (normally open)	1
10	JJGLD000168	Hexagon socket countersunk head screws M10X25	5
11	9XXDA000073	Turntable roller assembly	12
12	9XXDG00020 2	Pallet	2
13	9XXDG00020 1	Chain cover	1
14	JJSWG00000 8	Simple Turntable reducer	1
15	9XXDG00019 7	Motor housing welding parts	1
16	9XXDA000342	Turntable chain	1
17	9XXDG00015 3	Motor mounting plate	1
18	9XXDA000009	Turntable active sprocket	1
19	9XXDA000008	Gland	1

8.2.2 Exploded view and detail list

1) Exploded view of post assembly

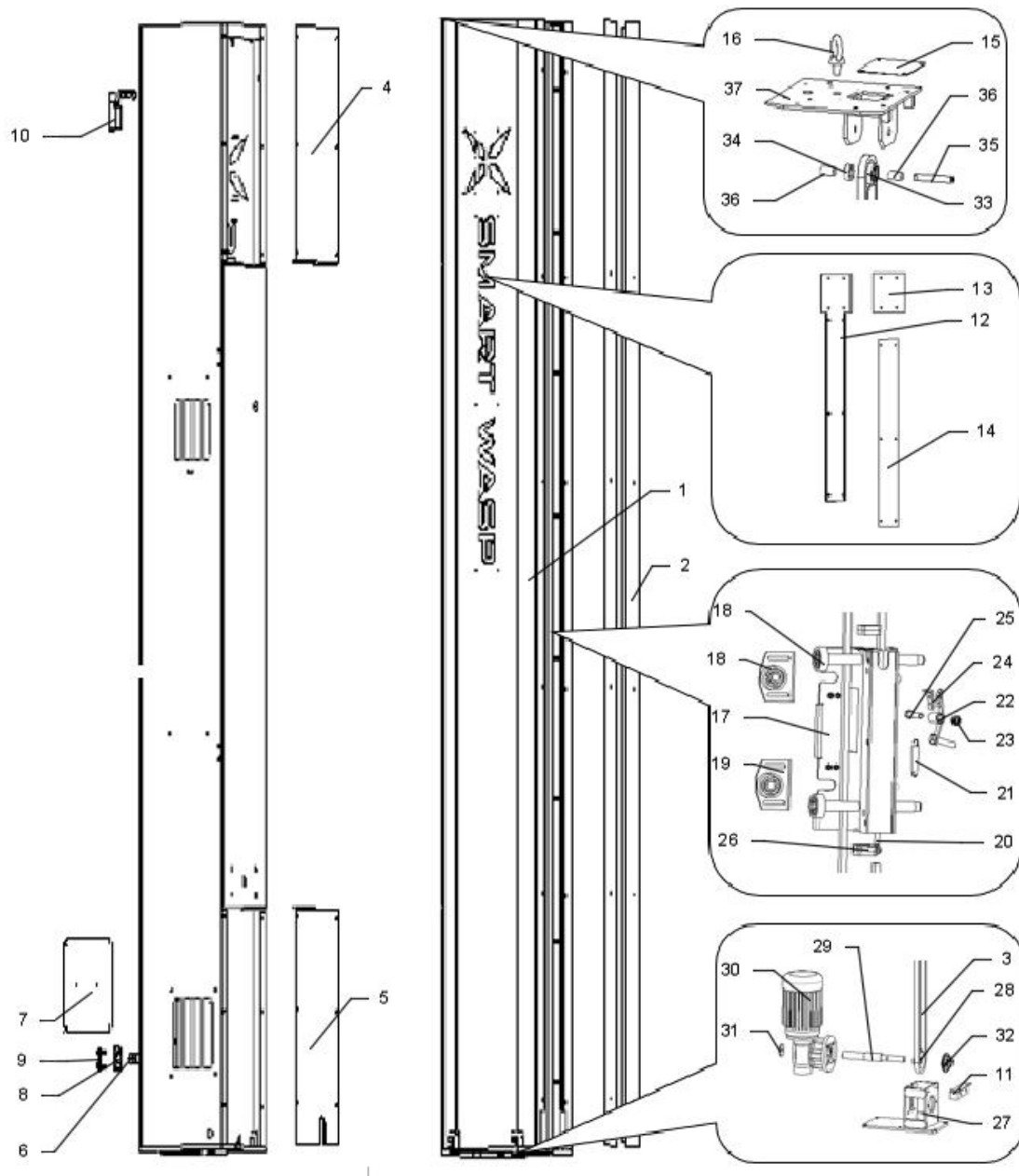

Serial number	Workpiece number	Artifact name	Quantity
1	9XXLM000401	Welding posts	1
2	9XXLM000355	Membrane Block Baffle	2
3	9XXDA000343	tower chain	1
4	9XXLM000193	Upper cover	1
5	9XXLM000283	Lower cover	1
6	DKGJJ000001	Proximity switch (normally open)	1
7	9XXLM000356	Rear cover	1
8	9XXLM000221	Photoelectric switch moving board	1
9	9XXLM000331	Photoelectric switch fixing plate welding parts	1
10	DKGXZ000001	Limit switch	1
11	9XXLM000387	Motor limit plate	1
12	9XXLM000405	Light box	1
13	9XXLM000425	Light guide 1	1
14	9XXLM000426	Light guide 2	1
15	9XXLM000412	Driven wheel upper cover	1
16	9XXDA000344	M16 rings	1
17	9XXLM000358	Trolley welding parts	1
18	JQTQT000160	Rubber-coated bearing pulley (17 × 50 × 18)	8
19	9XXLM000366	Guide wheel mounting plate	2
20	JJGLS000304	Joint bolt M10 × 40	1
21	JTHLX000021	Extension spring	1
22	9XXLM000368	Film carriage protection mechanism	1
23	JJGLM000020	Lock nut M10	2
24	9XXLM000052	Chain platen	1
25	9XXDA000345	Half tooth bolt M10	1

Smart Wasp

26	9XXLM000371	Cushion board	2
27	9XXLM000373	Power frame	1
28	9XXLM000263	Lifting main sprocket	1
29	9XXLD000068	Lifting spindle	1
30	JJSWG000009	Lifting trolley motor	1
31	9XXDA000008	Gland	1
32	JZCDZ000001	Block bearing SBPFL204	1
33	9XXLM000065	Lifting from sprocket	1
34	JZCSG000013	Deep groove ball bearings 6202	1
35	9XXLM000232	Driven wheel	1
36	9XXLM000192	Driven wheel bushing	2
37	9XXLM000407	Roof welding	1

8.2.3 Exploded view and detailed list of the Film carriage

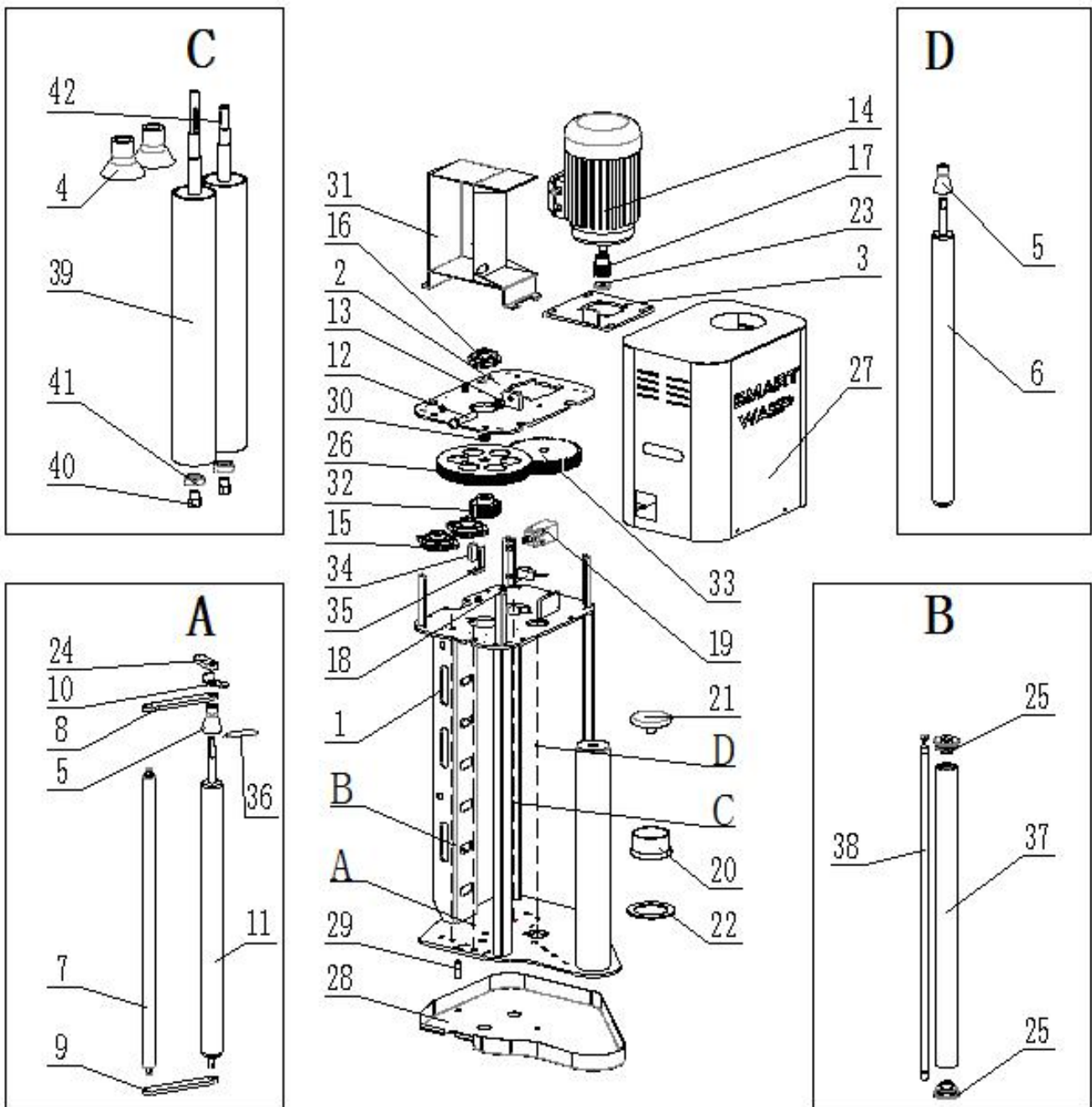

Serial number	Workpiece number	Artifact name	Quantity
1	9XXSM000266	Film carriage Welding Parts	1
2	9XXSM000287	Motor connection plate welding parts	1
3	9XXSM000280	Motor base tension plate	1
4	9XXSM000122	Membrane sleeve	2
5	9XXSM000123	Aluminum roll through film sleeve	2
6	9XXSM000166	No power roller 1	1
7	9XXSM000147	Aluminum alloy roller	1
8	9XXSM000277	Upper rotating plate	1
9	9XXSM000278	Lower rotating plate	1
10	9XXSM000282	Swivel arm gasket	1
11	9XXSM000293	No power roller 2	1
12	JJGLS000079	Hexagon head bolt M10X60	1
13	JJGLM000043	M10 nut	1
14	9JJP0000416	0.37kw motor	1
15	JZCDZ000001	Block bearing SBPFL204	2
16	9JJP0000417	BDC-202 bearing housing	1
17	9XXSM000176	Poly V-belt pulley	1
18	DKGJJ000001	Proximity switch (normally open)	1
19	9XXSM000148	Position switch CLS-103	1
20	9XXSA000056	Film under the fixed sleeve	1
21	9XXSA000057	Film roll top fixing piece	1
22	9XXSA000055	Film roll bottom gasket	1
23	9XXLM000267	Motor shaft end cap	1
24	9XXSM000276	Spring seat lever	1
25	9XXSM000265	Limit switch bush	2
26	9XXSM000299	V-ribbed pulley 170	1
27	9XXSM000273	Membrane housing	1

28	9XXSM000291	Bottom cover	1
29	9XXSM000171	Activity head	1
30	9XXSM000279	Poly-V-belt upper sleeve	1
31	9XXSM000301	Electrical control box	1
32	9XXSM000205	Cylindrical gear 26 × 2	1
33	9XXSM000206	Cylindrical gear 65 × 2	1
34	LH00114	Photoelectric switch	1
35	9XXLM000430	Photoelectric switch bracket	1
36	9XXSM000305	Film carriage rod spring	1
37	9XXSM000113	Movable roller assembly	1
38	9XXSM000290	Anti-collision shaft	1
39	9XXSM000264	Output drive roller	1
40	9ZZZX000023	Roller connecting shaft	2
41	JZCSG000008	Deep groove ball bearing	2
42	9XXSM000262	Pull film drive roller	1

8.3 Wearing parts

Serial number	Artifact name	Workpiece number	model	Brand	Quantity
1	Limit switch	DKGXZ000001	D4V-8108SZ-N	OMRON	2
2	Proximity switch (normally open)	DKGJJ000001	IQE17-05NNSK W2S	SICK	3
3	Bearing Nylon	9XXDI000073	With bearing 6202	smart wasp	19 groups
4	Conversion belt	9XXAA000080	B18.5-t2-L1660	smart wasp	1
5	Stop spring	9XXAA000086	Wire diameter ϕ 1	smart wasp	1
6	Conversion spring	9XXAA000011	Wire diameter ϕ 1.8	smart wasp	1
7	Film roll	9XXSA0000	Outsourcing	smart wasp	1

Smart Wasp

	bottom gasket	55			
8	Film under the fixed sleeve	9XXSA0000 56	Outsourcing	smart wasp	1